



AIR HANDLING UNIT



BlauAir/BlauAir Pro

EN

USER'S MANUAL

CONTENTS

Safety requirements.....	3
Purpose.....	4
Design.....	4
Designation key	5
Installation and set-up.....	8
Connection to power supply	14
Start-up preparations.....	16
Automation.....	17
Test run	17
Operation and maintenance.....	17
Control measurements of operating parameters.....	22
Storage and transportation rules.....	23
Manufacturer's warranty.....	24
Certificate of acceptance.....	27
Seller information.....	27
Installation certificate.....	27
Warranty card.....	27

This user's manual is a main operating document intended for technical, maintenance, and operating staff.

The manual contains information about purpose, technical details, operating principle, design, and installation of the BlauAir/BlauAir Pro unit and all its modifications.

Technical and maintenance staff must have theoretical and practical training in the field of ventilation systems and should be able to work in accordance with workplace safety rules as well as construction norms and standards applicable in the territory of the country.

SAFETY REQUIREMENTS

All operations described in this manual must be performed by qualified personnel only, properly trained and qualified to install, make electrical connections and maintain ventilation units.

Do not attempt to install the product, connect it to the mains, or perform maintenance yourself. This is unsafe and impossible without special knowledge.

Disconnect the power supply prior to any operations with the unit.

All user's manual requirements as well as the provisions of all the applicable local and national construction, electrical, and technical norms and standards must be observed when installing and operating the unit.

Disconnect the unit from the power supply prior to any connection, servicing, maintenance, and repair operations.

Connection of the unit to power mains is allowed by a qualified electrician with a work permit for the electric units up to 1000 V after careful reading of the present user's manual.

Check the unit for any visible damage of the impeller, the casing, and the grille before starting installation. The casing internals must be free of any foreign objects that can damage the impeller blades.

While mounting the unit, avoid compression of the casing! Deformation of the casing may result in motor jam and excessive noise.

Misuse of the unit and any unauthorised modifications are not allowed.

Transported air must not contain any dust or other solid impurities, sticky substances, or fibrous materials.

Do not use the unit in a hazardous or explosive environment containing spirits, gasoline, insecticides, etc.

Do not close or block the intake or extract vents in order to ensure the efficient air flow.

Do not sit on the unit and do not put objects on it.

The information in this user's manual was correct at the time of the document's preparation.

The Company reserves the right to modify the technical characteristics, design, or configuration of its products at any time in order to incorporate the latest technological developments.

Never touch the unit with wet or damp hands.

Never touch the unit when barefoot.

BEFORE INSTALLING ADDITIONAL EXTERNAL DEVICES, READ THE RELEVANT USER MANUALS.



THE PRODUCT MUST BE DISPOSED SEPARATELY AT THE END OF ITS SERVICE LIFE.

DO NOT DISPOSE THE UNIT AS UNSORTED DOMESTIC WASTE.

PURPOSE

The BlauAir/BlauAir Pro air handling unit consists of a number of connectable assembly units with various design to enable numerous composition options for various air handling processes. The unit is designed for air conditioning, ventilation with heat recovery, air heating, cooling, dehumidification or humidification, depending on available functioning components.

The air capacity ranges from 295 cfm (139 l/s) up to 50 000 cfm (23600 l/s). The air handling unit is designed for ventilation of residential, commercial, industrial building, trade centres, exhibition halls, etc.

Each air handling unit is designed individually for a customized ventilation network.

No warranty for full-featured operation of the unit in case of its use in a ventilation network possessing other parameters than the rated ones.



THE UNIT SHOULD NOT BE OPERATED BY CHILDREN OR PERSONS WITH REDUCED PHYSICAL, MENTAL, OR SENSORY CAPACITIES, OR THOSE WITHOUT THE APPROPRIATE TRAINING.

THE UNIT MUST BE INSTALLED AND CONNECTED ONLY BY PROPERLY QUALIFIED PERSONNEL AFTER THE APPROPRIATE BRIEFING.

THE CHOICE OF UNIT INSTALLATION LOCATION MUST PREVENT UNAUTHORISED ACCESS BY UNATTENDED CHILDREN.

The unit is rated for continuous operation.

Transported air must not contain any flammable or explosive mixtures, evaporation of chemicals, sticky substances, fibrous materials, coarse dust, soot and oil particles or environments favourable for the formation of hazardous substances (toxic substances, dust, pathogenic germs).

DESIGN

The unit consists of a number of blocks enclosed in a casing, made of rigidly fixed heat- and sound-insulated panels, 20-50 mm (13/16" - 1 15/16") thick, made of galvanized steel or aluzinc and filled with mineral wool.

Extra structural stability may be attained due to use of a mounting frame made of rolled steel.

The automation and control system enables operation of the air handling units for air conditioning with the set parameters and controls the air handling processes for each type of the unit configuration.

The outdoor modification of the unit is designed for mounting and operation outside of the building, under the roof. The air handling unit must be equipped with a drain pipe to protect the unit against atmospheric precipitation.

The drain pipe is equipped with a fine mesh to prevent ingress of mechanic objects up to 10 mm (3/8") in size.

The unit design is regularly improved, so some models may slightly differ from those ones described herein.

DESIGNATION KEY

RANGE

BlauAir

BlauAir Pro

RANGE NAME

BL

Unit air capacity m³/h x 1000

CASING TYPE

F

N

L

K

CASING SIZE

02

03

04

06

07

09

12

15

20

22

27

35

45

55

65

85

SERVICE SIDE

L

Left-handed modification

R

Right-handed modification

—

Bespoke modification

UNIT TYPE

EXH

Exhaust units

SU

Supply units

SE

Units with heat recovery core

CORE TYPE

R

Rotary

P

Crossflow

CR

Crossflow compact

CF

Counterflow

CORE MODIFICATION

EF

Enthalpy (with moisture transfer)

—

Standard

INSTALLATION TYPE

O

Outdoor

—

Indoor

HEATER TYPE

HE

Electric

HW

Water

—

No heater

COOLING COIL TYPE

CDX

DX-coil

CW

Water

—

No cooling

SEPARATE SECTIONS

F

Bag-type filter

FC

Panel filter

EC

Fan with EC motor

SRI

Silencer

HU

Humidifier

MC

Mixing chamber

HP

Heat pump

IB

Inspection block

D

Air damper

UV

UV-lamps

WH

Straight weather hood

WF

Twist weather hood

MB

Base frame

EVA

Flexible connection

RT

Rooftop

FRF

Roof

CONTROL PANEL





*S__

S__ - with control system

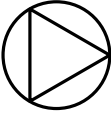

—

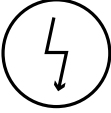
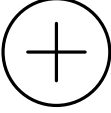
— - No control system

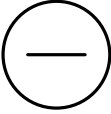
S*__ (where * — numeral designation from 0 to 9, their combination or space indicating the number of automation).

SECTIONS	
Ventilation section	
	<p>The air handling units have centrifugal direct-driven plug fans. The fan has backward-curved impellers. Depending on modification the fans must be installed on a sturdy frame supported with rubber vibration dampers to be customized selected to minimize transmission of vibration to the housing of the air handling unit. The fan casing is connected with a housing of the air handling unit through a flexible anti-vibration connector to cut vibration to the housing of the air handling unit.</p>
Heat recovery section	
	<p>The plate heat exchanger section may be equipped with a cross-flow or a counter-flow heat exchanger. The heat exchanger plates are sealed with an elastic thermal sealant and are locked with each other. Sealing of the heat exchanger plates ensures partition of the air streams in the heat exchanger. The heat recovery section may be equipped with a droplet separator to prevent drifting of condensed water drops with air streams. A droplet separator consists of multiple-folded plastic plates. The water drops are separated because of frequent air direction changes and are accumulated in the plate bends. The water drops are accumulated on the impeller blades and then are drained to the drain pan. Applied for the air handling units with the internal air velocity above 2.5 m/s to prevent drifting of condensed water drops in the air ducts.</p>
	<p>The rotary heat exchanger section consists of a heat wheel driven by electric motor belts. The rotary heat exchanger is made of aluminium band and has a cellular structure. The brush sealing around the heat wheel serves to minimize air backflow. The rotary heat exchanger is available with a fixed or controllable rotation speed. An integrated electronic speed controller ensures smooth speed control and maintaining the optimal temperature mode.</p>
Electric heater section	
	<p>An electric heater is used for supply air reheating. The heater is enclosed in a galvanised steel casing. Extra fins of the heating elements enlarge the heat exchange area. The electric heater has two overheat protection thermostats.</p>
Water heater section.	
	<p>A water heater is used for supply air reheating. The heater is enclosed in a galvanised steel casing. The heating coils are made of copper tubes and the heat exchange surface is made of aluminium. Hot water or ethylene glycol solution with max. operating temperature 150 °C (302 °F) are used as a heat medium. Connection of the water heaters to the heating network may be performed with threaded, flanged or welded joints. The water heater may be equipped with temperature gauge taps enabling installation of an automatic freeze protection system.</p>
Gas heater section	
	<p>The units use a gas heater to heat the supply air. The heater casing is made of welded sheet steel, the combustion chamber is made of stainless steel, the heat exchange elements are made of high quality steel with low thermal load, the front flue manifold is made of stainless steel, the heat exchanger inspection and cleaning, and the rear exhaust manifold is made of stainless steel.*</p>
Germicidal UV section	
	<p>For disinfecting air with ultraviolet radiation in ventilation systems.*</p>
Cooling section	
	<p>The units may comprise a water or DX cooler to reduce the supply air temperature. The cooler casing is made of galvanized or stainless steel and comprises copper pipes with aluminium finning. Cold water, ethylene glycol solution or Freon gas are used as a heat medium. The cooling section may be equipped with a droplet separator to prevent drifting of condensed water drops with air streams. A droplet separator consists of multiple-folded plastic plates. The water drops are separated because of frequent air direction changes and are accumulated in the plate bends. The water drops are accumulated on the impeller blades and then are drained to the drain pan. Applied for the air handling units with the internal air velocity above 2.5 m/s to prevent drifting of condensed water drops in the air ducts.</p>

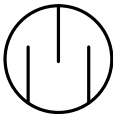
*For detailed information, refer to the installation and operating instructions for the respective section.

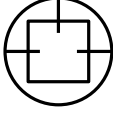
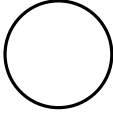
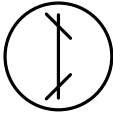
SECTIONS	
Filter section	
	<p>The filters enable filtration of supply and exhaust air streams and prevent contamination of heat exchangers and automation units as well as filter clogging.</p> <p>Coarse filters ensure first step filtration of the air stream prior to subjecting it to the more efficient fine filters.</p> <p>The integrated coarse and fine filters ensure high-quality air filtration of supply air.</p> <p>The filters may be of panel and bag-type with a metal frame design.</p> <p>A panel filter has a compact design. The low installation depth of the filter ensures efficient internal space utilisation.</p> <p>The folded structure creates a large filtering surface.</p> <p>The filter has low air resistance and a long service life.</p> <p>The coarse filter effectively prolongs the service life of the main filter.</p> <p>A bag filter has a special pocket-like shape. Thus, it is featured with a large filtering surface and outstanding dust capability.</p> <p>The filter has an extended service life and low maintenance costs. The filter consists of series of filtering cells ranging from the G3 (MERV 6) to the F9 (MERV 16) class (coarse and fine filter).</p> <p>The quality and long service life of the filters in the course of the unit operation are ensured by easy access to the filters for clogging control as well as their convenient cleaning and replacement.</p>
Silencer	
	<p>The plate silencers serve for attenuating the noise generated by the unit and auxiliary equipment during operation.</p> <p>The silencer consists of galvanized steel plates internally filled with a sound absorbing fire-resisting insulation material, extra protected with a synthetic fiber.</p> <p>The noise absorbing plates have a special coating to protect the sound-absorbing material.</p>
Humidifier section	
	<p>The humidifier section is used for air humidification and/or cooling.</p> <p>The humidifier section provides additional air cleaning with water drops.</p> <p>The humidifier section may be equipped with a droplet separator to prevent drifting of condensed water drops with air streams.</p> <p>A droplet separator consists of multiple-folded plastic plates.</p> <p>The water drops are separated because of frequent air direction changes and are accumulated in the plate bends.</p> <p>The water drops are accumulated on the impeller blades and then are drained to the drain pan.</p> <p>Applied for the air handling units with the internal air velocity above 2.5 m/s to prevent drifting of condensed water drops in the air ducts.</p>
Air mixing section	
	<p>The air mixing section enables mixing of supply and exhaust air streams.</p> <p>Regulation of ratio of the air streams is performed with manual or automatic air dampers.</p>
Inspection section	
	<p>An inspection section is a casing with an inspection door.</p> <p>This section is installed between components requiring inspection and maintenance.</p> <p>The inspection section is used in cases when any of the air handling unit components must be subjected to regular measurements.</p> <p>The section may be equipped with an inspection window and internal lighting for additional convenience.</p> <p>The empty section is installed between the air handling unit sections to contain sensors (i.e. temperature sensor) and to enable subsequent replacement with a different section of the air handling unit.</p>
Air damper	
	<p>The air damper is designed for automatic shutoff of the air duct during the system shutoff.</p> <p>The dampers contain counter-rotating aluminium shutters with high aerodynamic performance.</p> <p>The shutters may be equipped with extra cold proof heat insulation for extreme temperature conditions.</p> <p>Smooth air flow control is ensured by means of the gear drive made of robust heat-resistant plastic.</p> <p>The damper operation is controlled by means of the spring-return electric drive for guaranteed locking of the damper shutters in the closed position in case of an emergency power outage.</p>
Flexible connector	
<p>Flexible connector is designed to cut off vibration transmission from the fans to the air ducts and to partially compensate for the air duct assembly deformations caused by temperature variation.</p> <p>The flexible connectors consist of two flanges connected with vibration-absorbing material.</p> <p>The vibration connector is not intended to withstand any significant mechanical loads and, therefore, may not be used as load-bearing structures.</p>	

INSTALLATION AND SET-UP



READ THE USER'S MANUAL BEFORE INSTALLING THE UNIT.



**ALL OPERATIONS DESCRIBED IN THIS USER'S MANUAL MUST BE PERFORMED BY QUALIFIED PERSONNEL ONLY, PROPERLY TRAINED AND QUALIFIED TO INSTALL AND MAINTAIN VENTILATION EQUIPMENT.
DO NOT ATTEMPT TO INSTALL THE PRODUCT YOURSELF. IT IS UNSAFE AND IMPOSSIBLE WITHOUT SPECIAL KNOWLEDGE.**

Condensate drainage

The components of the unit that have a condensate drain must be equipped with a trap to ensure that the casing is watertight and that water can be drained out uninterrupted through the drainage spigot on both the suction and discharge sides.

Recommendations for organizing condensate drainage are given below.

All components of the system are not included in the delivery set of the unit and must be purchased separately.

The manufacturer of the ventilation system is not liable for the operability of the condensate drainage system installed at a particular facility.

When installing the units on the floor, allow sufficient distance from the floor to the bottom of the unit to fit the entire condensate drainage system.

A trap must be provided at each drainage spigot, separating it from the drainage pipe. Multiple outlets must not be connected to a common trap.

The drainage pipes must have a downward slope of at least 3°, without any tapering or loops, so as not to obstruct the water flow.

Due to the positive or negative air pressure inside the air handling unit, water cannot drain out of the condensate drip tray by itself. Therefore, it is necessary to connect a trap of a suitable height or a trap with a one-way valve to the drainage pipe. The trap must have a water level that is high enough to counteract the pressure drop between the internal and external space.

The height of the trap is selected based on the static pressure inside the air handling unit (the static pressure is specified in the technical data sheet for the unit).

- only use the positive value for calculations;
- take into account the final pressure drop (filter, etc.).

For a trap with no one-way valve, the height **H** is determined by the static pressure **p** using the formula:

H [mm] = 25 + **p**, if the pressure is expressed in mm of the water level.

H [mm] = 25 + 0.1**p** if the pressure is expressed in Pa.

The figures below illustrate the geometric features of the traps.

The suction side. Negative pressure ($p < p_{\text{atmospheric}}$)

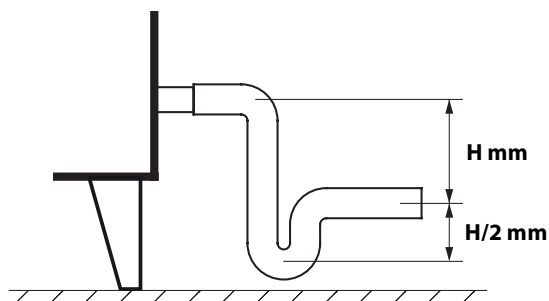

The discharge side. Positive pressure ($p > p_{\text{atmospheric}}$)

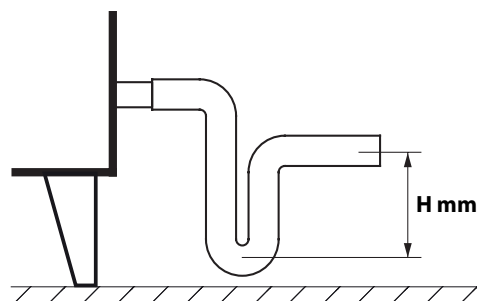

If the trap is equipped with a one-way valve, the height can be reduced, but this depends on the technical data of the trap. It is recommended to choose the height similarly to the trap without a one-way valve.

The figure below illustrates a schematic example of a trap with a one-way valve.

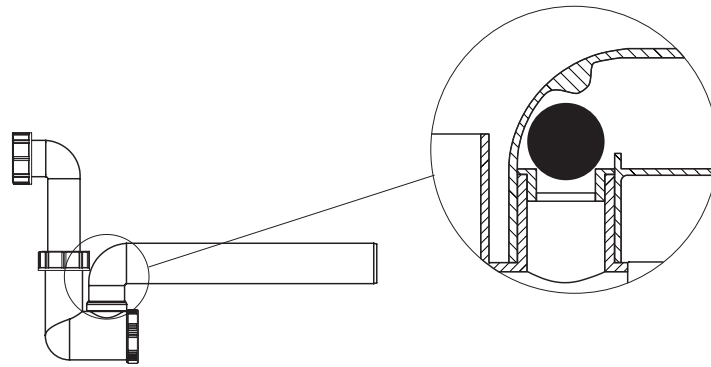

Fill up the U-traps with water before using the system.

The trap must be filled with water at all times as long as the system is operating.

The condensate drainage system should not be directly connected to the common sewage system to avoid polluting the air with bacteria and odors.

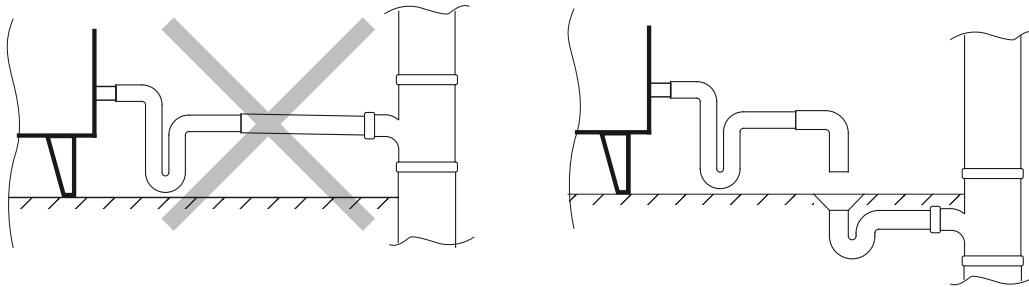

To prevent the water from freezing over in winter, the pipeline laid outdoors or in unheated rooms must be equipped with heat insulation and pre-heating.

The units are available in the left-hand and right-hand modifications to enable maintenance access on either the left or the right side. The maintenance side is marked depending on its position relative to the direction of air supply to the premises. The maintenance side determines the position of the heater (cooler) fittings and condensate drain pipes.

Left-hand modification

Right-hand modification

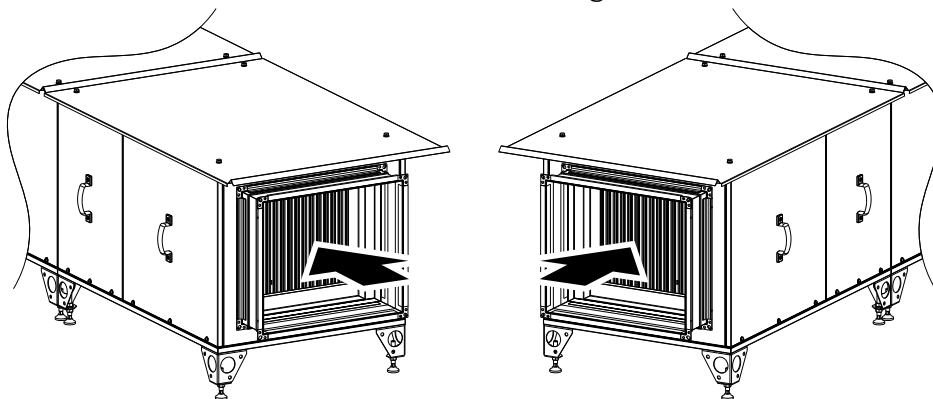

For residential installation only.

Read carefully the Safety Requirements regulations prior to assembly of the air handling unit (page 2).
 Check all the unit sections for mechanical damages.
 Check the unit for completeness.
 The unit must be mounted to a smooth hard surface.
 The quality and stability of the surface intended for the unit installation must be verified by a duly qualified person.
 It is essential to place the unit above the mounting deck level.
 The frame and the levelling feet enable unit mounting at an elevation of up to 180 mm (7 1/16").
 If the U-trap height exceeds the maximum mounting elevation (see the calculation table below), the unit must be mounted above the deck level to create the clearance required for the U-trap installation.

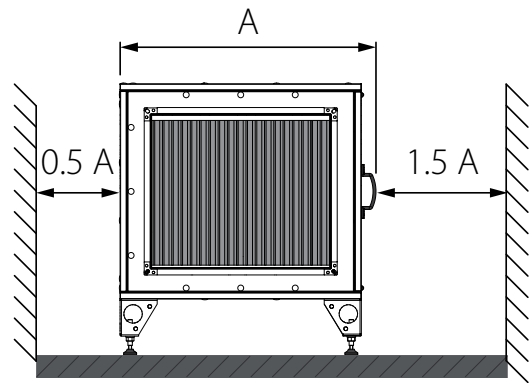

Installation on a frame with a levelling feet

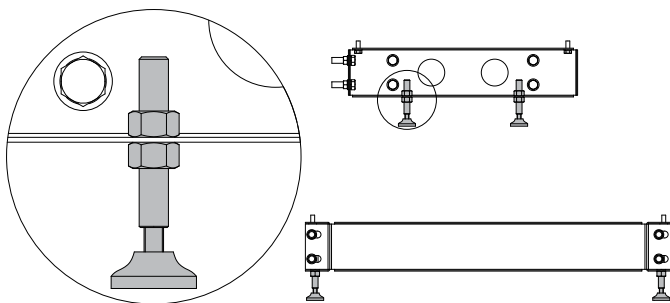

Installation on brackets with a levelling feet

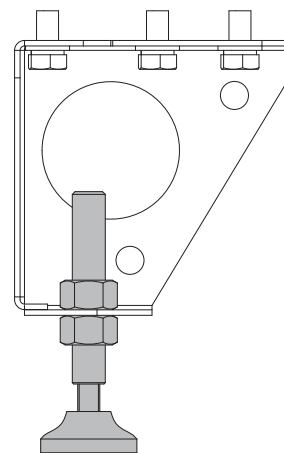

Connection of the unit sections

The unit sections are bolted and may be installed on a mounting frame if required.
 The piled sections are interconnected with a coupling bracket.
 Each of the unit sections is uniquely marked to ensure convenience of operation and prevent improper installation and maintenance.

WARNING!

Do not connect the unit sections with ratchet tie-down straps!

The sections are interconnected with M8x60 screws and nuts, washers and wedge lock washers.
 To connect the unit sections, open the service panels first and tie them up with bolts through fastener holes.
 The mounting frames of separate sections or levelling feet must also be tied up.

WARNING!

Tightening of the sections start with x-shaped brackets inside the sections!

Place nuts on bolts manually to avoid damage of a rivet nut.

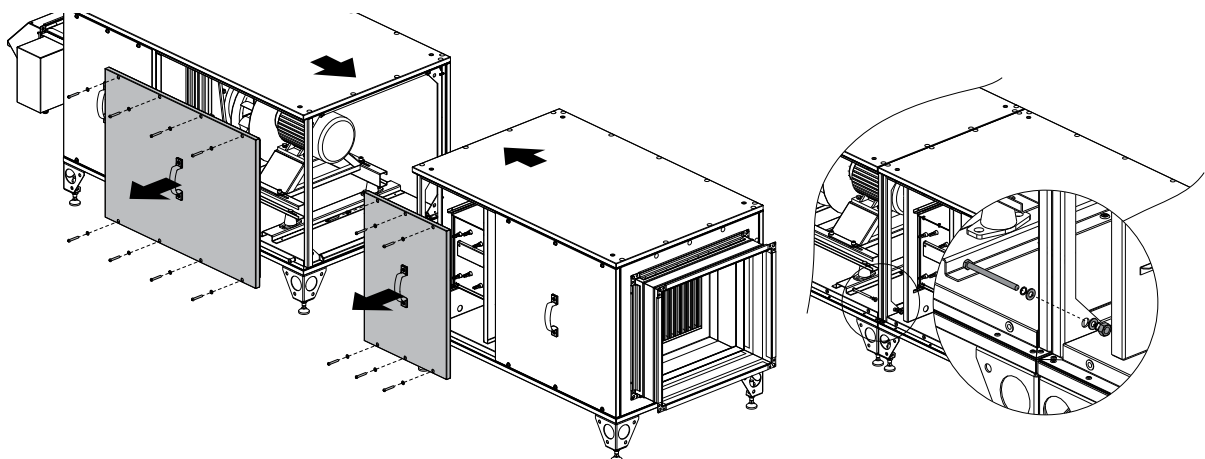

The piled sections are interconnected with coupling brackets and screws, nuts, washers and wedge lock washer. The coupling brackets are installed during mounting of the section.

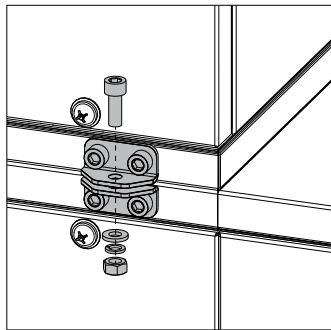

The roof of the units in the outdoor modification which have been delivered in sections must be mounted only after joining the sections. All the roof joints must be insulated with a joint filler on the inside. Treat the screws with a sealant prior to screwing in to enable good sealing of the joints.

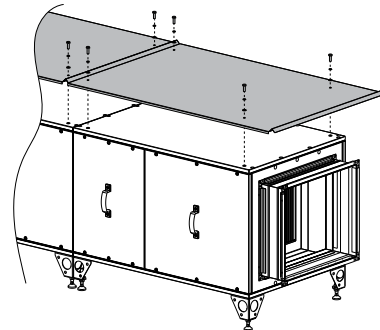

Connection of air ducts, rainscreen hoods and ducts components to the unit

The air duct must be connected to the units by means of elastic anti-vibration connectors which attenuate the vibrations transmitted by the unit to the air ducts. The anti-vibration connectors also compensate for any misalignment while joining the units with the air ducts. The anti-vibration connectors are bolted to the air ducts.

The connected equipment and the air ducts must be equipped with individual fastenings to avoid the transfer of own weight load onto the unit.

Connection of water heating or cooling sections

Any mounting and wiring operations of the hydraulic system must be performed by qualified technicians only!

The circulation pump must be grounded.

The power cable must not be in contact with the pipeline or the pump.

The hot or cold medium flow direction must be opposite to the air flow.

WARNING!

On connection of a water heater and/or water or dx cooler the length of straight pipeline sections must be at least 400 mm (15 3/4") from the unit (as shown below).

Any shorter length will prevent opening of the service panels.

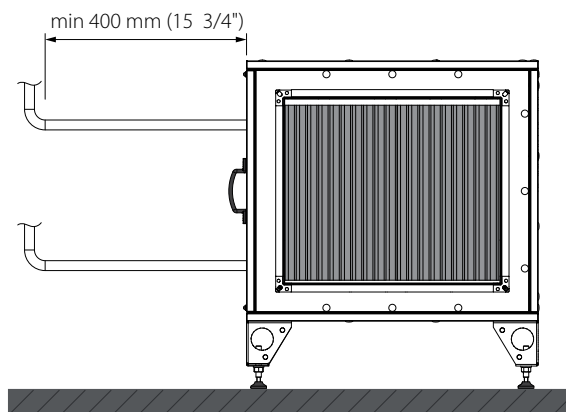

The heater and cooler connections must be subject to zero mechanical loads on the feed pipeline side.

The water pressure must remain below 1.5 MPa (6022 inWG).

It is recommended to use shutoff valves which block the hot or cool water supply in case of an emergency dismantling without draining the heat transfer agent from the equipment.

Connection diagram to municipal water mains

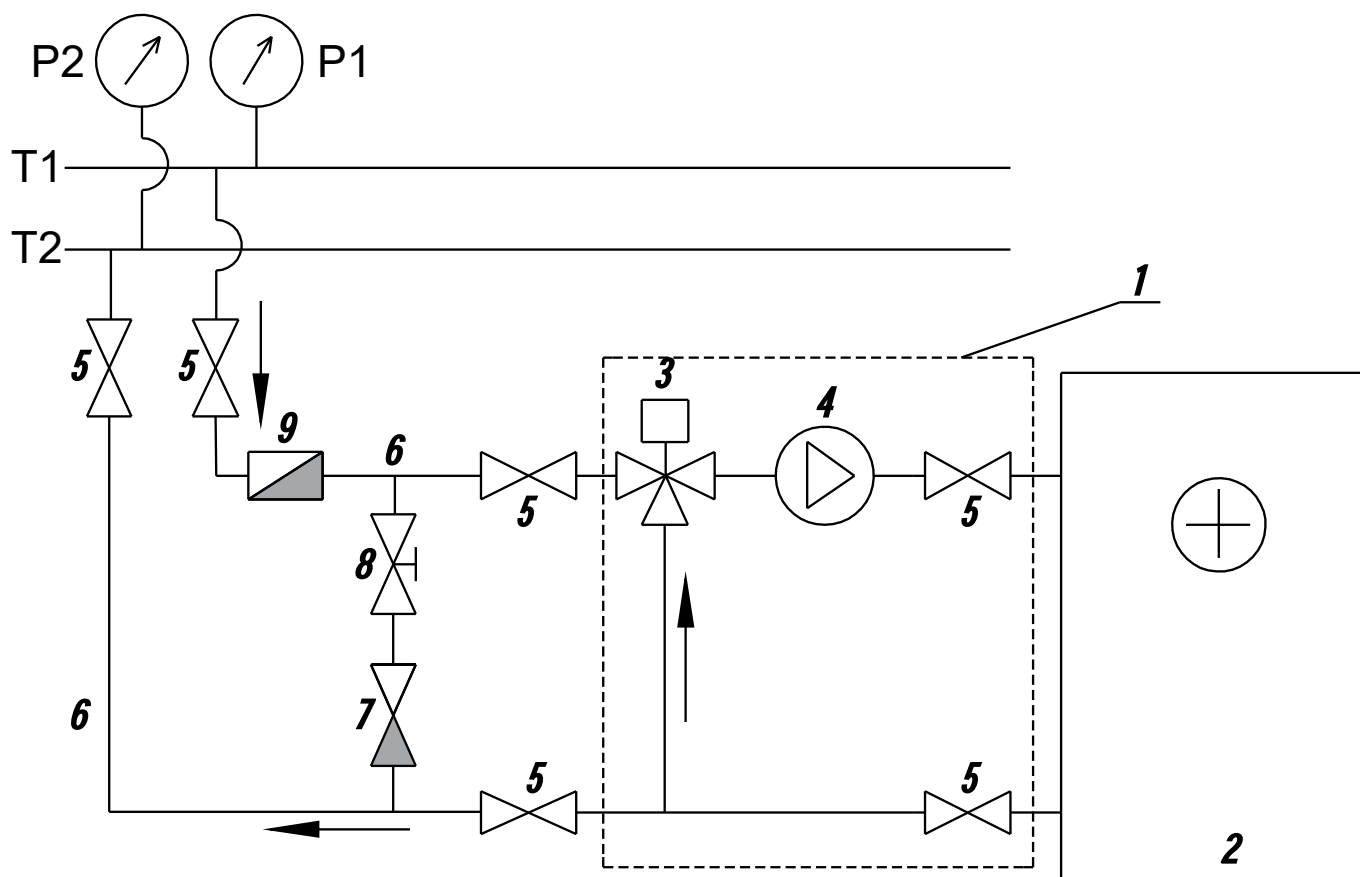

T1 and T2 - supply and return pipelines of heating/cooling system

P1 and P2 - liquid pressure gages in the heat distribution system

1 - WMG mixing unit

2 - water heater

3 - three-way valve with actuator

4 - circulation pump

5 - shut-off valve

6 - supply and return pipeline connection between heating system and water heater

7 - non-return valve

8 - balancing valve

9 - coarse filter

The design of the unit sections is such that they cannot be cantilevered. Each section must be supported in the designated locations. The upper sections that protrude beyond the edge of the lower ones must be supported by an appropriate structure (elements for fastening / suspending are not included in the delivery set).

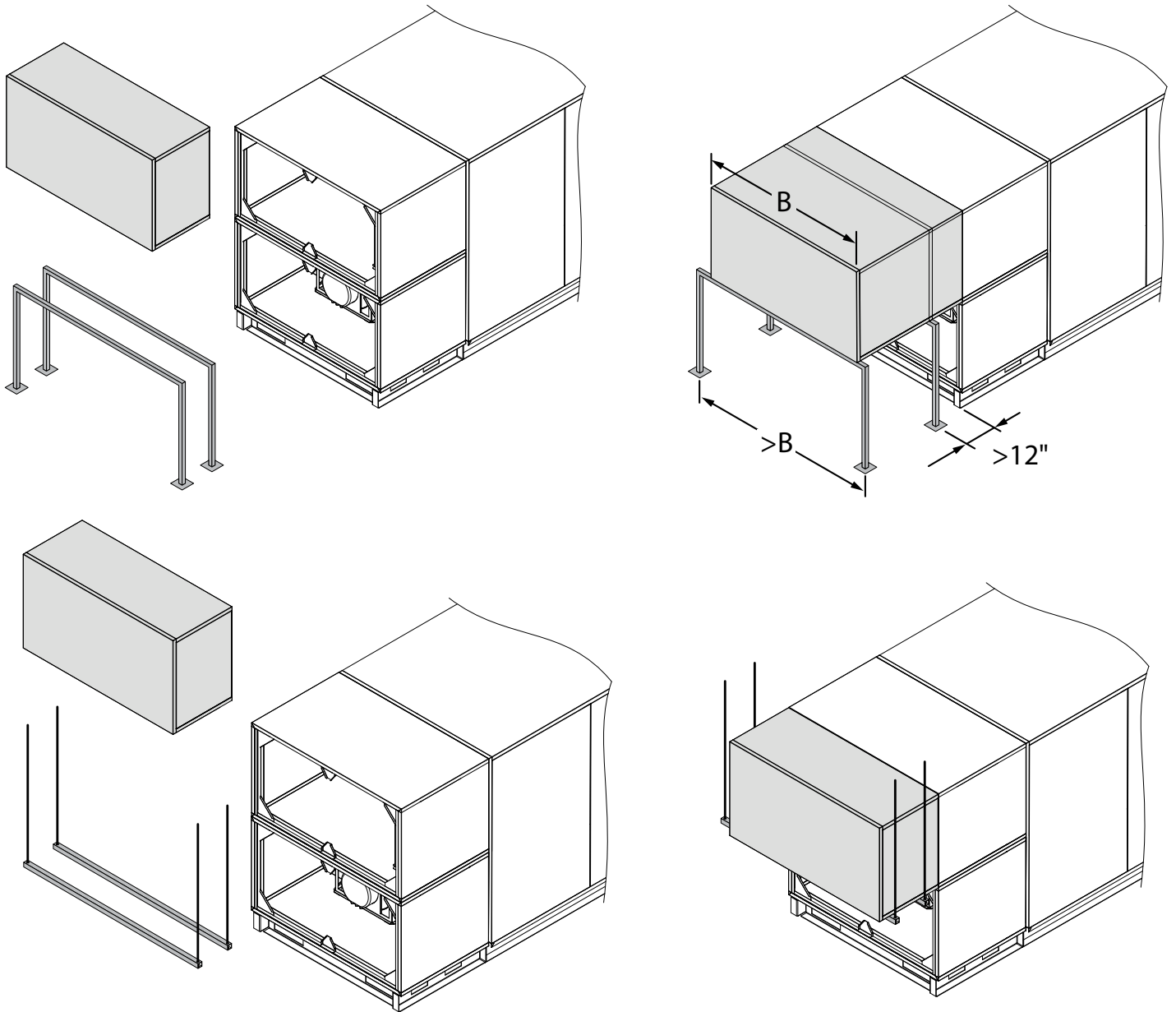

CONNECTION TO POWER SUPPLY

THE UNIT CONNECTION TO THE POWER SUPPLY MUST BE PERFORMED BY DULY QUALIFIED PERSONNEL MADE FAMILIAR WITH THE PRESENT OPERATION MANUAL. THE UNIT IS INTENDED FOR CONNECTION TO AC MAINS SUPPLYING THE VOLTAGE COMPLIANT WITH THE TECHNICAL SPECIFICATION CHART. CHECK THE ENTIRE POWER CORD LENGTH FOR CHOKING. DO NOT SWITCH ON THE UNIT IF THE CABLE IS DAMAGED.

DISCONNECT THE UNIT FROM POWER SUPPLY PRIOR TO ANY OPERATIONS.

THE RATED ELECTRICAL PARAMETERS OF THE UNIT ARE STATED ON THE RATING PLATE.

WARNING!

CONNECTION OF THE ELECTRICAL ELEMENTS OF THE PRODUCT MUST BE CARRIED OUT BY APPROPRIATELY QUALIFIED AND AUTHORISED PERSONNEL AND ALSO IN ACCORDANCE WITH THE NORMS AND STANDARDS APPLICABLE IN THE COUNTRY OF INSTALLATION.

ELECTRICAL CONNECTIONS MUST NOT COMPROMISE THE TIGHTNESS AND FUNCTIONALITY OF THE PRODUCT.

ELECTRICAL CONNECTIONS MUST BE ADAPTED TO THE CONDITIONS AT THE PLACE WHERE THE PRODUCT IS INSTALLED (TEMPERATURE AND HUMIDITY, TYPE OF CABLE LAYING, DISTANCE TO THE SWITCHBOARD, ETC.)

THE PRODUCT MUST BE EQUIPPED WITH A CIRCUIT BREAKER.

FAILURE TO COMPLY WITH THESE REQUIREMENTS WILL INVALIDATE THE WARRANTY.

Fan connection

All the connections must be made in accordance with the technical specifications for the automatic control system.

The electric power supply must comply with the following specifications:

- Voltage: voltage within 0.9 ...1.1 of the rated value;
- Frequency: 0.99...1.01 of the nominal frequency at all times and 0.98...1.02 at peak times.
- For supply connections, use wires suitable for at least 70 °C (158 °F).

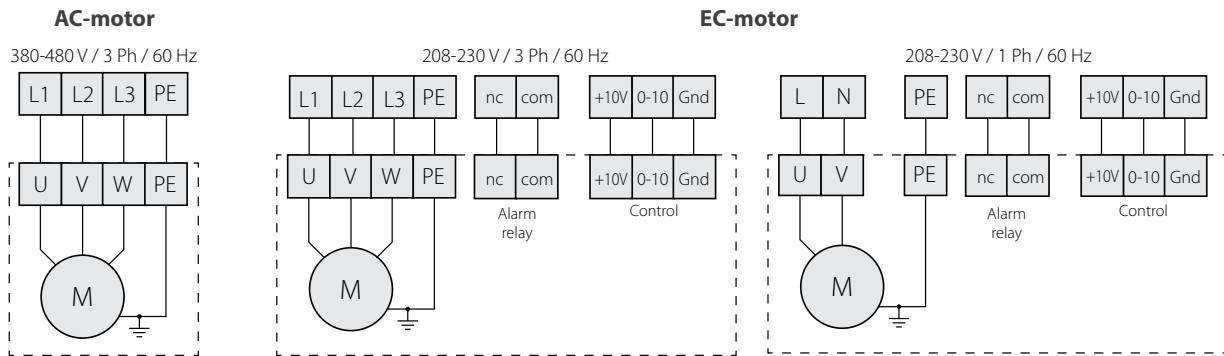

Electric heater connection

The electric heaters are equipped with overheat protection thermostats which activate at 50 °C (122 °F) (automatic reset) and 90 °C (194 °F)(manual reset). Wiring of the electric heaters is shown on the diagram on the right.

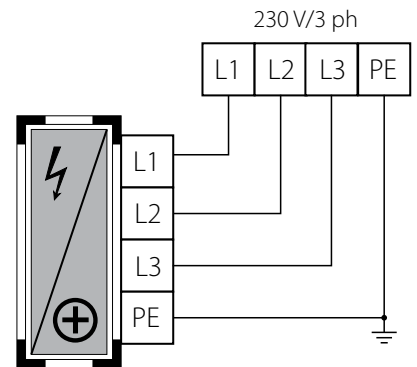

Air damper connection

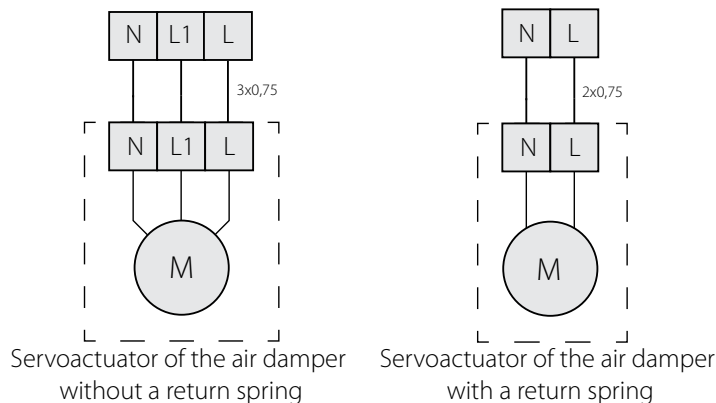

Connection of pressostats

The pressostat on the filter must be installed in such a way so that its pipe marked with the (-) symbol is routed via a tube to the lower pressure area (downstream of the filter) whereas the pipe marked with the (+) symbol is routed to the higher pressure area (upstream of the filter).

The pressostat on the fan must be installed in such a way so that its pipe marked with the (-) symbol is routed via a tube to the lower pressure area (upstream of the motor) whereas the pipe marked with the (+) symbol is routed to the higher pressure area (downstream of the motor).

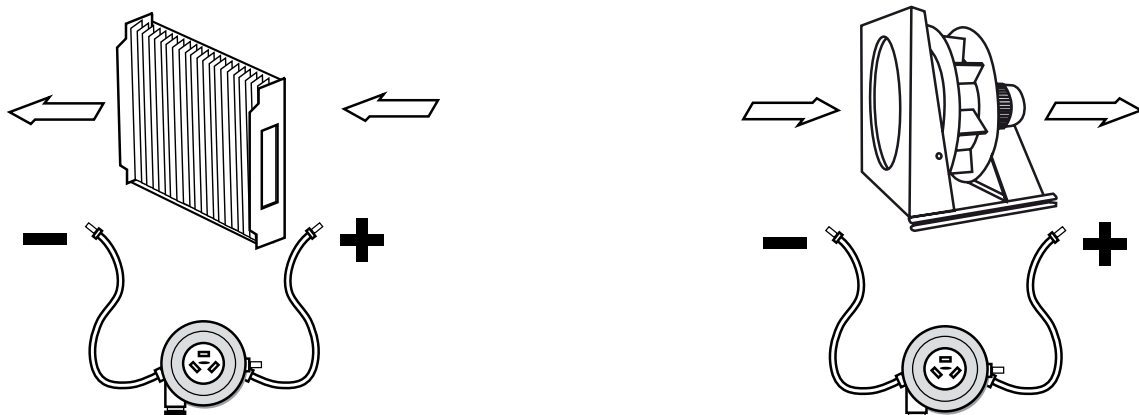

START-UP PREPARATIONS

The permanent operation must be preceded by start-up preparations.

Such a start-up must only be performed by the properly qualified and trained personnel.

Prior to the test run the personnel must study the instructions and schematic diagrams being part of the technical documentation of the unit and perform the following steps:

- Check the unit for proper installation.
- Check all the ventilation devices for proper connection to the power supply.
- Make sure all the hydraulic and electrical connections are properly connected to the to the respective sections of the unit.

Electrical equipment

Check the electrical equipment for proper connection, insulation integrity and grounding against the electrical connections diagram and the technical parameters of the components.

Further inspect the electric wires and the power consumers visually for insulation integrity.

The installation operations must comply with the provisions of the unit-specific technical documentation.

Any non-compliance of the installation work with the technical documentation shall void the manufacturer's warranty for the unit.

If the installation has been performed by the manufacturer's engineers, the electrical equipment and the entire unit shall be covered by the identical warranty for the air handling unit.

Electric heaters

Make sure the heater is clean and intact.

Connect the heater in accordance with the wiring diagram.

The connected heater must not be in contact with other elements of the units.

Water heaters

Check the pipelines for proper connection (supply and return lines) and then inspect the condition of the heater plates.

Adjust the settings of the freeze protection thermostat (factory setting +5 °C (41 °F)) in succession as well as the tightness of the capillary contact with the heater surface.

The heat medium control valve controlling the heater operation must be installed in accordance with the markings on the housing.

DX, water and glycol coolers

Check the condition of the cooler plates and the supply and return pipelines for proper connection.

Then check the droplet separator for proper installation relative to the air flow and then perform the same with regards to the U-trap.

Filters

Check the filters for proper attachment, their density and general condition.

The detailed filter specifications shall be checked against their respective documentation.

Cross-flow plate heat exchanger

Check the heat exchanger surface for any contamination and mechanical damage.

Check the droplet separator (if available) for proper installation relative to the air flow, and then perform the same with regards to the U-trap. If the heat exchanger is equipped with a bypass, check the air shutters, dampers and electric actuator mounting.

Rotary heat exchanger

Make sure that the heat exchanger cells are clean and free from damage.

Check the belt tension with the spring attached to the motor base and adjust it, if necessary. Check the control unit mount (if available).

Fan section

Check the fan section prior to starting the unit.

Make sure that the section is free from any foreign objects such as the yellow-colour transportation fasteners and assembly components.

Failure to do so may result in the unit damage. The fan impeller must have a smooth running.

Then check the following:

- The electrical connections against the wiring diagrams.
- The fan motor for proper connection (the mains voltage must comply with that one on the motor rating plate).
- The ground wire for proper connection if the fan is mounted on rubber anti-vibration dampers.
- The rubber anti-vibration dampers in the fan section for proper installation.
- All the wires in the fan section for proper clamping.

If all the above steps are successfully completed, all the unit doors may be closed.

AUTOMATION

Automation is an integral part of each supplied air handling unit. It enables smooth control and failsafe operation of the unit, prevents possible operation problems and alarms.

This user's manual contains no data or guidelines for mounting of the automation system components, connection, commissioning and operation of the system.

This information is available in the supplied technical documentation for a delivered automation system type.

Otherwise the supplier of the automation system must provide the required information.

The control unit may be supplemented with extra controls like air damper actuators, frequency converters, pressure and temperature sensors, CO₂ sensors, constant air flow sensors, humidifiers, triac controllers.

Operation manuals for the automation system components are supplied separately.

TEST RUN

The unit start-up preparations and the test run must only be performed by specially trained and duly qualified personnel.

Prior to starting the fans check the air dampers for proper operation.

Correct and safe operation of the unit is provided only in case of connection to designed ductwork system.

After the start-up let the unit run for approximately 30 minutes.

During the test operation measure the electrical equipment current and the unit air capacity.

Absence of elevated noise levels, abnormal noises or smells generated by the unit or vibration registered during the test run suggests successful commissioning of the air handling unit.

If the results suggest otherwise, troubleshoot any malfunctions in the unit operation.

On registering any of the above phenomena disconnect the unit from power supply and double-check each of its sections.

After the unit power-off and before opening the panels make sure that the unit impeller has come to a full stop.

If this cannot be confirmed visually, do not open the panels until 3 minutes after the power-off.

If no malfunctions occur within a 30-minute test run the unit can be switched off and inspected.

Inspect:

- The filter mounts;
- Condensate removal efficiency;
- Motor temperature and the condition of the fan group bearings.

Upon checking all the connections check the ant-vibration dampers for proper operation.

If allowed by the climatic conditions, check the freeze protection thermostat operation.

Such check may be carried out when the supply air temperature is lower than the thermostat temperature threshold.

Should this be the case temporarily shut off the heat medium supply to the heater at the supply air temperature of +1..2 °C (+34 ..35 °F).

Thermostat activation indicates its proper operation.

If the test run is performed during the warm season, check the thermostat operation at the earliest opportunity during the nearest cold season.

OPERATION AND MAINTENANCE

The air handling units are designed for continuous operation.

Therefore, to ensure proper unit performance schedule periodic checks with special attention given to the life-limited parts such as filters and bearings.

Filter replacement and cleaning are not be considered as warranty cases.

The basic technical details required for the regular inspection are given on the technical specification chart provided with each device.

The chart contains the view and dimensions of the essential elements such as filters, heat exchangers, fans and electric motors.

Filters

The air conditioning units are equipped with pocket and panel filters.

Combination and location of the filters depends on functional composition of the unit.

It is essential during filter replacement to use the filter with the identical filtration class.

Filter clogging reduces its capacity and decreases the unit performance.

The filter must be replaced if the filter pressure falls below the critical threshold.

Abnormal filter contamination levels may result in an increased air flow rate in the units which may eventually cause filter warping and even fan damage.

During the filter replacement the units must be disconnected from power supply.



CAUTION! ELECTRIC SHOCK MAY RESULT DISCONNECT POWER BEFORE SERVICING UNIT

The coarse filter replacement frequency mainly depends on the air pollution level.

Proper coarse filter operation significantly extends the useful life of the fine filters.

Electric terminals

The electric terminals of all the electrical parts of the unit require periodic checking and tightening to prevent contact scorching and equipment malfunction.

Water heater

The water heater is equipped with a freeze protection thermostat as standard.

On heat medium supply shutoff or in case of an interruption in the unit operation with the ambient air temperature below + 4 °C (+ 39 °F) the heater must be drained of the heat medium (except using the 40 % glycol mixture).

Contamination of the heater surface reduces its performance.

Therefore, check the heater plates for contamination.

Dust on the heater plates may also contribute to air resistance increase.

Clean the heaters with a vacuum-cleaner on the air supply side, compressed air jet or washing with a mild water solution of neutral detergents non-corrosive for the aluminium plates.

Electric heater

The electric heater contains open coils which may accumulate dust during the unit inactivity.

An extensive contamination may generate a smell of burned dust or, in the worst-case scenario, a fire upon the subsequent heater start.

Check regularly the technical condition and contamination levels of the heaters and electrical connection .

Only dry cleaning is allowed.

Water cooler:

The water cooler maintenance is identical to that of the water heater.

In addition check the cooler and droplet separator for any dirt as well as for the condensate drain pipe obstruction.

To remove contamination, clean the cooling coils with a mild water solution of a neutral detergent.

DX cooler

The operation and maintenance for the DX coolers are identical to those of the water heater and the water cooler.

Make sure that the DX cooler is disconnected from power supply before cleaning.

Failure to do so may result in an uncontrolled Freon pressure spike and cooling equipment damage.

Cross-flow heat exchanger

The heat exchanger maintenance includes checking the plates for contamination and its technical condition.

Clean the cross-flow heat exchanger with a vacuum-cleaner, compressed air jet or washing the air ducts with a mild water solution of a neutral detergent non-corrosive to the aluminium surfaces.

Check the droplet separator condition (if available), the condensate drain pan and the condensate removal system.

If the heat exchanger is equipped with a bypass air damper, inspect the bypass damper actuator and check the stroke of the damper shutter.

Rotary heat exchanger

While performing the rotary heat exchanger maintenance make sure to check the cell condition.

The surface must be free from any contaminations or mechanical damage.

Check the belt tensioning regulated by the spring mounted to the motor base.

Check the control unit mount (if available).

Clean the rotary heat exchanger with a vacuum-cleaner, compressed air jet or washing the air ducts with a mild water solution of a neutral detergent non-corrosive to the aluminium surfaces.

Air damper and air shutter

Check the air dampers periodically.

The shutters and gears may accumulate dust, grease and other contaminants preventing proper operation of the dampers.

If present, remove contamination with compressed air jet.

If such actions fail, subject the damper to a high-pressure wash with a water solution of a detergent non-corrosive to the aluminium surfaces.

Ventilation equipment maintenance regulation

	Component name	once a week	once per month	every 6 months	once a year
1.	Supply filter*:				
	Inspection of the condition	-	+	-	-
	Dust removal, compressed air jet	-	(!)	+	-
	Replacement	-	-	-	+
2.	Extract filter*:				
	Inspection of the condition	-	+	-	-
	Dust removal, compressed air jet	-	(!)	+	-
	Replacement	-	-	-	+

Ventilation equipment maintenance regulation

	Component name	once a week	once per month	every 6 months	once a year
Control switchboard:					
3.	Check-up of communication lines and power cables for integrity	-	+	-	-
	Check-up of terminal connections	-	+	-	-
	Check-up of launch protection equipment	-	+	-	-
	Checking controller operation, analysis of error log	+	-	-	-
	Temperature sensor reading analysis	+	-	-	-
	Verification of set parameters of the frequency converter	-	-	-	+
	Verification of the temperature sensor readings	+	-	-	-
	Operation checking of the frequency converter of the rotor drive	-	-	-	+
	Operation checking of protective circuit	-	+	-	-
Water heater:					
4.	Visual inspection	-	-	+	-
	Cleaning and washing	-	-	-	+
	Operation check-up of the 3-way heat medium control valve (if the system is filled with heat medium) and the circulation pump	-	-	+	-
Electric heater:					
5.	Visual inspection	-	+	-	-
	Cleaning	-	-	+	-
	Check-up of the electric heating elements	-	-	+	-
Water cooler:					
6.	Visual inspection	-	+	-	-
	Cleaning (together with the droplet separator)	-	-	-	+
DX cooler:					
7.	Visual inspection	-	+	-	-
	Cleaning (together with the droplet separator)	-	-	-	+
Cross-flow heat exchanger:					
8.	Visual inspection	-	+	-	-
	Check-up of the drain pan	-	+	-	-
	Check-up of the drain system and U-trap	-	+	-	-
	Check-up of the bypass damper and damper actuator	-	+	-	-
	Heat exchanger cleaning	-	-	-	+
Rotary heat exchanger:					
9.	Check-up of the rotor smooth rotation	-	+	-	-
	Check-up of the belt condition and tightening	-	+	-	-
Exhaust/Supply air shutters:					
10.	Check-up of the shutters smooth operation	-	-	+	-
	Checking of the electric actuator and electric connections	-	-	+	-
	Damper cleaning	-	-	+	-
Back airflow damper with shutters					
11.	Checking air shutters for smooth operation	-	-	+	-
	Checking of the electric actuator and electric connections	-	-	+	-
	Damper cleaning	-	-	+	-
Supply and extract fans:					
12.	Visual inspection and check-up of the electric motors and impellers	-	+	-	-
	Check-up of the motor fixation and vibration dampers on the mounting frame in the fan section	-	+	-	-
	Check-up of the terminal connections in the motor terminal box	-	-	+	-
	Test run of the motor with and without load	-	-	+	-
	Checking of the impeller fixation to the motor shaft	-	+	-	-
	Checking of the indirect motor heating temperature under the rated operation conditions	-	-	+	-
	Current checking and measuring for each phase	-	-	-	+
	Verification of the frequency converter parameters	-	-	-	+
	Cleaning of the impeller and motor from dust	-	-	+	+

((!)) — more intensive contamination requires more frequent applications.

*— filter cleaning and replacement frequency may vary depending on the region and air pollution degree.

ALARMS

	Alarm	Alarm source	Possible troubles
1.	Fire signalling	External signal from the fire alarm system. The inputs of the external terminals are closed and the alarm signal is generated.	Check the inlet circuits.
2.	Supply fan	Operation signal from the supply fan frequency converter.	Check the frequency converter settings. Check the parameters of the controller inputs. These parameters must be consistent with the frequency converter parameters.
		Fan pressostat.	Check the fan operation. Check the pressostat operation. Check the thermostat capillary tube mounting.
3.	Extract fan	Operating signal of the extract fan frequency converter.	Check the frequency converter settings. Check the parameters of the controller inputs. These parameters must be consistent with the frequency converter parameters.
4.	Temperature sensor	Malfunction of any temperature sensor	Check the current temperature readings in the controller menu, see "Current status". If the controller reads the temperature -40 °C (-40 °F), it indicates a short circuit in the corresponding sensor circuit. If the controller reads the temperature +150 °C (302 °F), it indicates a circuit breakdown.
5.	Heat exchanger freezing	This alarm is generated if the temperature falls down below the set point within a set time period.	Check the parameters of the control pattern for the heat exchanger.
			Check the actuating device for operability.
			Check the exhaust air temperature for operability.
6.	Rotary heat exchanger	Operation signal from the rotary heat exchanger frequency converter.	Check the frequency converter settings. Check the parameters of the controller inputs. These parameters must be consistent with the frequency converter parameters.
7.	Heater freezing	Tripping of the freeze protection thermostat of the heater. The freeze protection function is activated also in the summer mode.	Set the thermostat tripping temperature from 8 to 10 °C (47 °F ... 50 °F). Check the thermostat control circuit. Check the settings of the operating contact for compliance.
8.	Low water temperature	Low heat medium temperature at the end of the heating cycle.	Check the heat medium. Check the pump. Check operation of the actuating device. Check heat medium flow.
9.	Low return heat medium temperature	Low heat medium temperature during operation.	Check the heat medium temperature. Check operation of the circulation pump. Check operation of the actuating device. Check heat medium flow and make sure the hydraulic system is not clogged.
10.	Circulation pump	No pump operation control.	Check the pump operability. Check operability of the control unit (pressostat, flow rate sensor, etc.). If a control unit is not available, jump the respective inputs.
11.	Supply filter	Supply filter clogging.	Check for clogging. Check the clogging control device (pressostat).
12.	Extract filter	Extract filter clogging.	Check for clogging. Check the clogging control device (pressostat).
13.	Heater overheating	Tripping of the overheating thermostat.	Check the supply air damper for opening, check the supply filter for clogging, check operability of the actuating device (relay).
14.	Low supply air temperature	Low supply air temperature within 10 minutes (scheduled) is interpreted as underheating.	Check the heating element and control circuit condition. Make sure that the environmental conditions of the installation place match the stated conditions.

TROUBLESHOOTING

	Problem	Possible source.	Troubleshooting method
1.	Filter alarm (clogging).	Filter clogging.	Clean the filter using a vacuum cleaner against air flow direction or install a new filter. (!) Do not wash the filter with water or detergents!
		Malfuction of the pressostat or breakdown of the commutation circuit (NC - normally closed contact).	Check the status of the pressostat or check its circuit (NC - normally closed contact).
2.	Low air flow.	Filter clogging, heater or heat exchanger contamination.	Clean the fan, the heater and the heat exchanger.
		Fan malfunction.	Check power supply to the fan. Check the control system for errors.
		One or two air dampers are closed.	Check the air damper for smooth opening. Check connection to power supply and available control signal on the damper actuator.
		Wrong rotation direction of the fan.	Check the three-phase motor for correct phase sequence. Check the capacitor capacity and its status for the single-phase motor. Check the software settings and the direction of rotation. (!) The rotation direction is shown on the impeller of the ventilation unit in the technical data sheet for the air handling unit.
3.	Water dripping in the unit.	Drain line clogging.	Clean the pipes.
		No U-trap.	Install the U-trap.
		Wrong unit-drain line mounting angle.	Check the installation angle of the air handling unit/drain line for consistence with the data stated in the technical documentation. Correct it if required.
4.	No heating (applicable for the air handling units with an integrated heater)	No power supply to the electric heating elements.	Check power supply to the heater section. Check resistance of each heating element and check them for integrity. In case of any breach on the circuit of the heating element replace it.
		Tripping of the thermal switch TK 90 °C.	Press the button ""Reset"" on the thermal switch TK90 for manual reset. (!) Troubleshoot the tripping source for TK90.
		No contact on the electric heating elements.	Press the connection lugs of the heating elements.
		Breaking of the electric heater element (wire breaking)	Replace the electric heating element.
		Breakdown of the solid-state relay.	Check the condition of the solid-state relay using a volt-ohm meter. Normally the relay does not acts as a conductor and is closed.
5.	Water heater/cooler has insufficient heating or cooling capacity.	No heat medium.	Check availability of the heat medium in the hydraulic system, its temperature and pressure.
		Air locks in the hydraulic system.	Deaerate the system.
		No heat medium circulation.	Check power supply to the circulation pump. Check the pump rotor for rotation.
		Malfuction or closing of the mixing unit.	Check power supply to the mixing unit actuator. Check the connection of the actuator to the actuating device.
		Open bypass damper.	Check the bypass damper actuator for jamming. Make sure it is properly connected to power supply and the bypass damper opening procedure matches the control system command.
6.	Abnormal noise generated by the unit.	Direct connection of the air duct to the casing without anti-vibration connector.	Do not allow the air duct to be connected directly to the unit.
		Run-out of the motor bearing service life.	Check rotation of the rotor with idle running. Noise and skirr may indicate the run-out of the bearing service life.

7.	Malfunction of one or two motors.	No power supply to the electric motors.	Check the voltage.
		Motor winding breakdown or turn-to-turn short circuit of the motor winding.	Check resistance of each motor winding using a volt-ohm meter.
		No control signal for EC motors.	Make sure the signal is available for specified status of the control system parameters. Check the control system for errors.
8.	Generation of condensate in inappropriate places in the unit.	Air motion inside of the unit during standstill caused by air draughts because of open dampers or no dampers.	Check operability of the supply and exhaust air dampers.
		Internal air leakages as a result of severe clogging of one or two filters.	Clean the filter using a vacuum cleaner against air flow direction or install a new filter. (!) Do not wash the filter with water or detergents!
		Inappropriate use of the air handling unit.	Check the transported air parameters (humidity + temperature) and the environmental parameters.

CONTROL MEASUREMENTS OF OPERATING PARAMETERS

The technical maintenance of the unit includes routine measurements of the following parameters:

- Correct temperature and humidity of the processed air both upstream and downstream of the air handling unit.
- The operating parameters of the components in the connected heating and cooling equipment.
- Proper operation of the electrical equipment (power consumption measurements).
- Proper operation of the fan groups specific to maintaining the air flow and unit operation parameters.

All the work specific to the routine control measurements and technical maintenance operations must be confirmed with the appropriate documents.

STORAGE AND TRANSPORTATION RULES



ATTENTION!

TRANSPORTATION AND HANDLING OPERATIONS MUST BE APPROACHED WITH CAUTION!

The unit is delivered to the site either fully assembled or in sections to undergo final assembly immediately on the site (depending on the complexity of the installation configuration or the customer's requirements). The blocks must not be piled vertically.

Any mechanical damage which may be caused by vertical piling shall not be covered under the manufacturer's warranty.

Depending on the standard size and weight of the unit (all the necessary information being given on the specification sheets on the unit) a variety of special transport devices can be used for loading and unloading operations such as a hoisting crane, a lifting beam or a forklift.

The holes in the unit base enable loading and unloading operations by means of a hoist crane.

The side protection of the units is provided by the buffer beams of appropriate length depending on the unit size.

The unit can also be loaded and unloaded by means of a lifting beam. In any case the side panels must be protected against accidental damage by the forklift or cables.

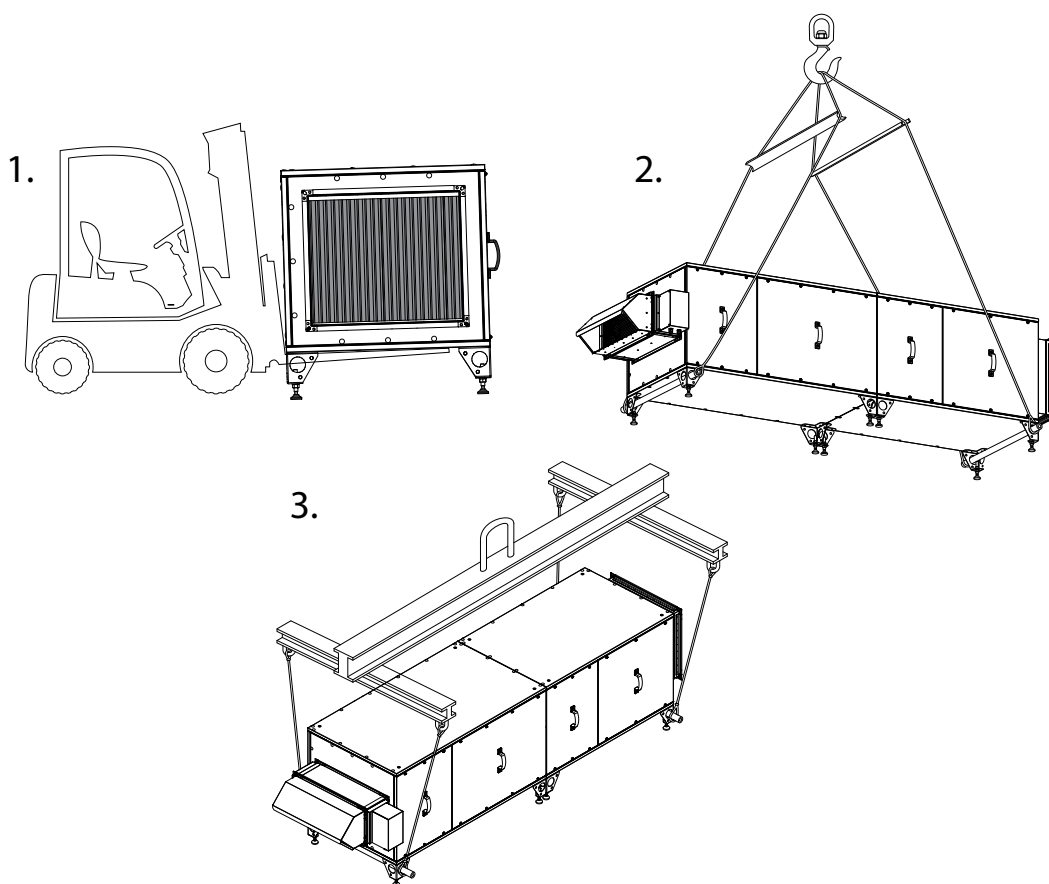



THE ROTARY HEAT EXCHANGER SECTIONS MUST BE TRANSPORTED WITH EXTREME CARE SO AS TO PREVENT AN ACCIDENTAL DAMAGE TO THE ROTARY HEAT EXCHANGER.

Upon delivery to the destination site check the unit for damage and the completeness of the accompanying documents.

The space intended for unit storage must meet the following basic requirements:

Protection against atmospheric precipitation;

Dry conditions with air temperatures from -20 °C ... +30 °C (-4 °F ... +86 °F);

Absence of aggressive environments, gases or dust which may lead to corrosion of the unit or its components.

The manufacturer's warranty does not cover any mechanical damage to the unit resulting from improper transportation, handling or storage.

MANUFACTURER'S WARRANTY

Production meets standard operating requirements in the USA and Canada.

Blauberg warrants to the original purchaser of the unit that it will be free from defects in materials or workmanship for a period of 24 months from the date of original purchase. The Blauberg warrants to the original purchaser of the unit that the integrated control unit will be free from defects in materials and workmanship for a period of 24 months from the date of original purchase.

THERE ARE NO OTHER WARRANTIES, EXPRESS OR IMPLIED, INCLUDING, BUT NOT LIMITED TO, IMPLIED WARRANTIES OF MERCHANTABILITY OR FITNESS FOR A PARTICULAR PURPOSE.

During the stated warranty period, Blauberg will, at its option, repair or replace, without charge, any product or part which is found to be defective under normal use and service. This warranty does not cover (a) normal maintenance and normal service or (b) any products or parts which have been subject to misuse, negligence, accident, improper maintenance or repair (other than by Blauberg), faulty installation or installation contrary to recommended installation instructions. Labor to remove and replace products is not covered. The duration of any implied warranty is limited to the time period specified for the express warranty. Some states do not allow limitations on how long an implied warranty lasts, so the above limitation may not apply to you.

BLAUBERG OBLIGATION TO REPAIR OR REPLACE, AT BLAUBERG OPTION, SHALL BE THE PURCHASER'S SOLE AND EXCLUSIVE REMEDY UNDER THIS WARRANTY. BLAUBERG SHALL NOT BE LIABLE FOR INCIDENTAL, CONSEQUENTIAL OR SPECIAL DAMAGES ARISING OUT OF OR IN CONNECTION WITH PRODUCT USE OR PERFORMANCE.

Some states do not allow the exclusion or limitations of incidental or consequential damages, so the above limitation or exclusion may not apply to you. This warranty gives you specific legal rights, and you may also have other rights which vary from state to state. This warranty supersedes all prior warranties. If proof of sales date is absent, warranty period is calculated from the production date. The unit can be exchanged at the following address:

Blauberg North America LLC
1501 Veterans Memorial Pkwy E, Ste. 202, Lafayette, IN 47905
Tel: (765) 780-7139
Fax: (661) 825-8895
info@blauberg-na.com

Please follow guidelines in this manual for product problem-free operation.



FOLLOWING THE REGULATIONS STIPULATED HEREIN WILL ENSURE A LONG AND TROUBLE-FREE OPERATION OF THE UNIT



USER'S WARRANTY CLAIMS SHALL BE SUBJECT TO REVIEW ONLY UPON PRESENTATION OF THE UNIT, THE PAYMENT DOCUMENT AND THE USER'S MANUAL WITH THE PURCHASE DATE STAMP

UNIT COMPONENTS	
Name	Number
Extract fan	
Supply fan	
Air filter	
Water heater	
Electric heater	
Water cooler	
DX cooler	
Plate heat exchanger	
Rotary heat exchanger	
Humidifier	
Dehumidifier	
Silencer	
Air damper	
Air damper with electric actuator	
Flexible connector	
Automation unit	
Other	

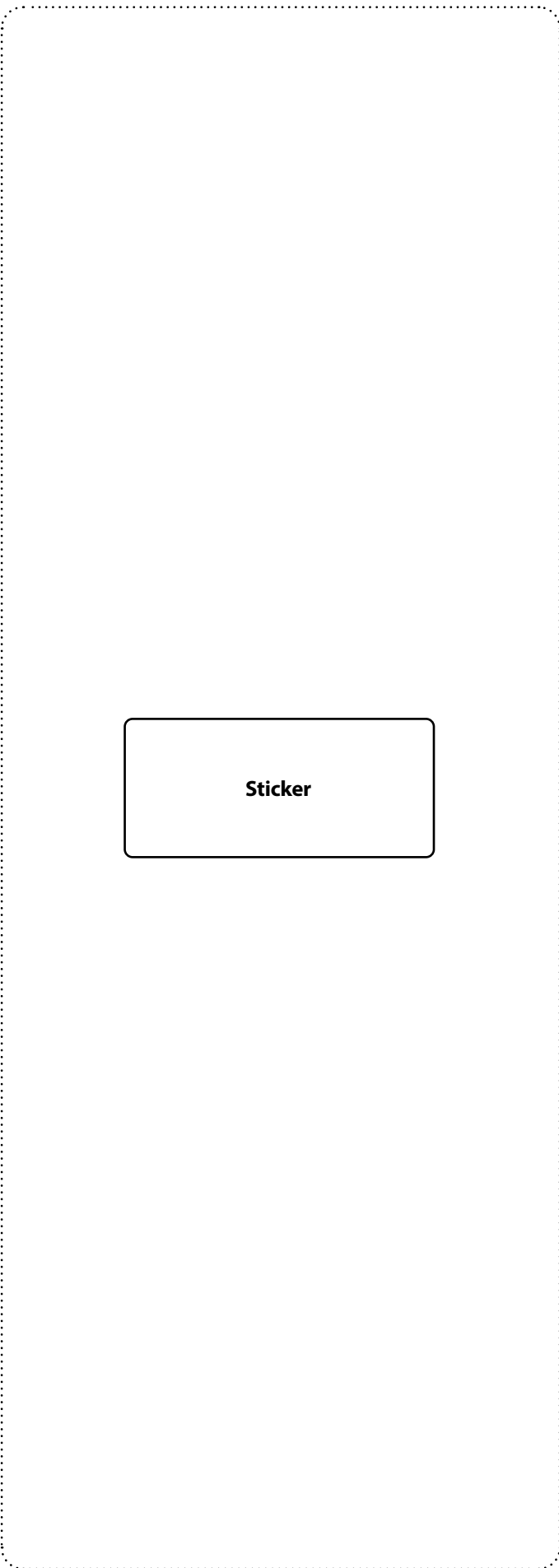

CERTIFICATE OF ACCEPTANCE

Unit Type	Air handling unit
Model	
Serial Number	
Manufacture Date	
Quality Inspector's Stamp	

SELLER INFORMATION

Seller	
Address	
Phone Number	
E-mail	
Purchase Date	
This is to certify acceptance of the complete unit delivery with the user's manual. The warranty terms are acknowledged and accepted.	
Customer's Signature	

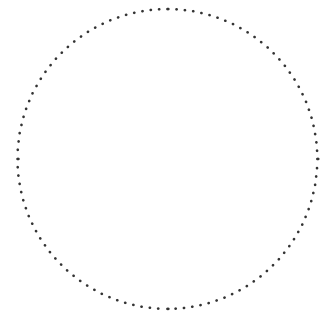

Seller's Stamp

INSTALLATION CERTIFICATE

The _____ unit is installed pursuant to the requirements stated in the present user's manual.	
Company name	
Address	
Phone Number	
Installation Technician's Full Name	
Installation Date:	Signature:
The unit has been installed in accordance with the provisions of all the applicable local and national construction, electrical and technical codes and standards. The unit operates normally as intended by the manufacturer.	
Signature:	

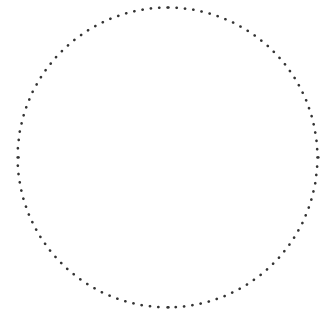

Installation Stamp

WARRANTY CARD

Unit Type	Air handling unit
Model	
Serial Number	
Manufacture Date	
Purchase Date	
Warranty Period	
Seller	

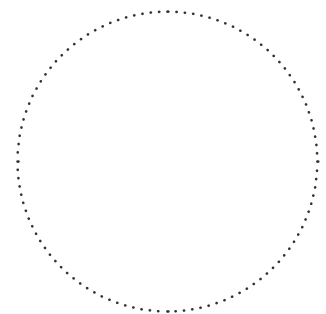

Seller's Stamp

