

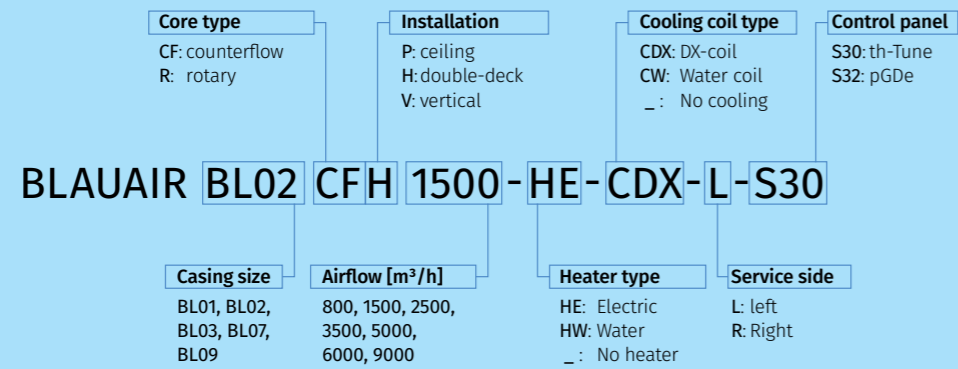

Select the unit online in a few clicks and get full technical data at [blaubergselector.com](http://blaubergselector.com)

### READING THE MODEL CODE



## BLAUAIR CFH

Floor mounted heat recovery units

Blauberg North America  
1501 Veterans Memorial Pkwy E, Ste. 202,  
Lafayette, IN 47905  
tel.: 765 780 7139

[info@blauberg-na.com](mailto:info@blauberg-na.com)  
[blauberg-na.com](http://blauberg-na.com)

Technical changes reserved.  
Illustrations and texts are non-binding.

07/2024



# BLAUAIR CFH

Premium range of floor mounted heat recovery units for commercial applications.

The unit is available in seven sizes with rated air flow 470–5295 CFM, with heaters and cooling coils.

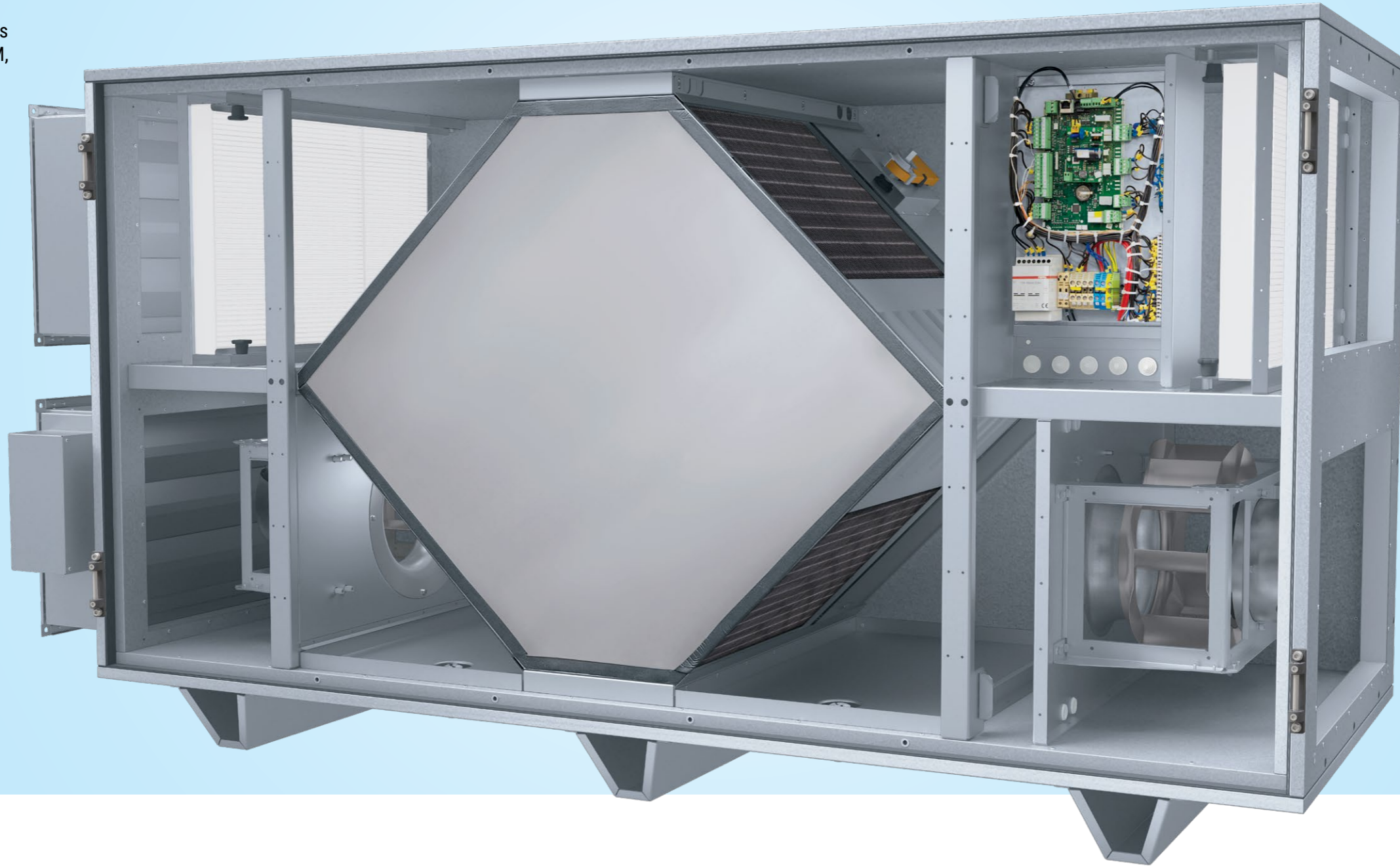

## FANS

**Fans with EC motors.** Impellers with backward-curved blades.

Low power consumption at any speed, low noise and stable operation in any climate.

## CONTROLS

Integrated plug-and-play controls based on **Carel kVent controller**.

### CAREL

Easy connectivity via Web interface by Ethernet cable. **Modbus** and **Bacnet** protocols.



## USER PANELS

**S30 th-Tune:** simple control panel ensures basic setting options with user-friendly interface.



**S32 pGDe:** extended control panel for full functionality engineering adjustment.



## FRAMELESS/WITH FRAME DESIGN

Casing panels made of zinc-aluminum coated steel with a 1 5/8" mineral wool heat- and sound-insulating layer. Corrosion class C4 according to ISO 12944: class C4. Each model available in left or right versions.

## HEAT EXCHANGER

High-efficient **Eurovent certified** counterflow heat exchanger made of profiled plastic plates, packed with elastic heat-resistant sealant. Stainless steel drain pan on both supply and exhaust sides.

## BYPASS AND DAMPERS

Automatic heat exchanger bypass damper with a **Belimo actuator** provides active frost protection, free-heating and free-cooling functions. Integrated automatic external dampers with Belimo drives.



## FILTERS

Panel MERV13 class filters on both supply and exhaust.