

AIR HANDLING UNIT

BLAULITE HRV 5/8/13/17/25
BLAULITE HRV 5/8/13/17/25 /O
BLAULITE ERV 5/8/13/17/25
BLAULITE ERV 5/8/13/17/25 /O

EN

USER'S MANUAL

CONTENTS

Safety requirements.....	3
Purpose.....	6
Delivery set.....	7
Technical data.....	7
Design and operating principle	8
Mounting and set-up.....	9
Connection to power mains	13
Unit control	18
Technical maintenance.....	20
Troubleshooting.....	21
Storage and transportation regulations.....	21
Certificate of acceptance.....	23
Seller information.....	23
Installation certificate.....	23
Warranty card.....	23

This user's manual is a main operating document intended for technical, maintenance, and operating staff.

The manual contains information about purpose, technical details, operating principle, design, and installation of the BLAULITE HRV/ERV 5/8/13/17/25 (I/O) unit and all its modifications.

Installation must be carried out only by experts and only in accordance with local requirements and national electrical code.

Technical and maintenance staff must have theoretical and practical training in the field of ventilation systems and should be able to work in accordance with workplace safety rules as well as construction norms and standards applicable in the territory of the country.

The information in this user's manual is correct at the time of the document's preparation.

The Company reserves the right to modify the technical characteristics, design, or configuration of its products at any time in order to incorporate the latest technological developments.

No part of this publication may be reproduced, stored in a retrieval system, or transmitted, in any form or by any means in any information search system or translated into any language in any form without the prior written permission of the Company.

SAFETY REQUIREMENTS

- Please read the user's manual carefully prior to installing and operating the unit.
 - All user's manual requirements as well as the provisions of all the applicable local and national construction, electrical, and technical norms and standards as well as national electrical code must be observed when installing and operating the unit.
 - The warnings contained in the user's manual must be considered most seriously since they contain vital personal safety information.
 - Failure to follow the rules and safety precautions noted in this user's manual may result in an injury or unit damage.
 - After a careful reading of the manual, keep it for the entire service life of the unit.
 - While transferring the unit control, the user's manual must be turned over to the receiving operator.
-
- **The unit must be grounded!**
 - **Do not bend the power cable.**
 - **Avoid damaging the power cable.**
 - **Do not put any foreign objects on the power cable.**
 - **Do not use damaged equipment or cables when connecting the unit to power mains.**
 - **Do not touch the unit controls with wet hands.**
 - **Do not carry out the installation and maintenance operations with wet hands.**
 - **Do not allow children to operate the unit.**
 - **Do not store any explosive or highly flammable substances in close proximity to the unit.**
 - **Do not open the unit during operation.**
 - **Do not block the air duct when the unit is switched on.**
 - **Do not sit on the unit and avoid placing foreign objects on it.**

- Unpack the unit with care.
- While installing the unit, follow the safety regulations specific to the use of electric tools.
- Do not lay the power cable of the unit in close proximity to heating equipment.
- Do not operate the unit outside the temperature range stated in the user's manual.
- Do not operate the unit in aggressive or explosive environments.
- Do not wash the unit with water*.
- Protect the electric parts of the unit against ingress of water.
- Disconnect the unit from power mains prior to any technical maintenance.
- When the unit generates unusual sounds, odor, or emits smoke, disconnect it from power supply and contact the Seller.
- Do not direct the air flow produced by the unit towards open flame or ignition sources.
- In case of continuous operation of the unit, periodically check the security of mounting.

* Only for AIRLIT ERV/HRV 5/8/13/17/25 US



THE PRODUCT MUST BE DISPOSED SEPARATELY AT THE END OF ITS SERVICE LIFE.

DO NOT DISPOSE THE UNIT AS UNSORTED DOMESTIC WASTE.



USE THIS UNIT ONLY IN THE MANNER INTENDED BY THE MANUFACTURER. IF YOU HAVE QUESTIONS, CONTACT THE MANUFACTURER.



**THE UNIT SHOULD NOT BE OPERATED BY CHILDREN OR PERSONS WITH REDUCED PHYSICAL, MENTAL, OR SENSORY CAPACITIES, OR THOSE WITHOUT THE APPROPRIATE TRAINING.
THE CHOICE OF UNIT INSTALLATION LOCATION MUST PREVENT UNAUTHORIZED ACCESS BY UNATTENDED CHILDREN.**



**READ THE USER'S MANUAL BEFORE INSTALLING THE UNIT.
INSTALLATION WORK AND ELECTRICAL WIRING MUST BE DONE BY QUALIFIED PERSON(S).
WHEN CUTTING OR DRILLING INTO WALL OR CEILING, DO NOT DAMAGE ELECTRICAL WIRING AND OTHER HIDDEN UTILITIES.
DO NOT MOUNT ROOM-TO-ROOM FAN IN A FIRE-RATED WALL.**



**POWER OFF THE POWER SUPPLY PRIOR TO ANY OPERATIONS WITH THE UNIT.
THE UNIT MUST BE CONNECTED TO POWER SUPPLY BY A QUALIFIED ELECTRICIAN.
THE RATED ELECTRICAL PARAMETERS OF THE UNIT ARE GIVEN ON THE MANUFACTURER'S LABEL.**



ANY TAMPERING WITH THE INTERNAL CONNECTIONS IS PROHIBITED AND WILL VOID THE WARRANTY.



INSTALLATION ONLY BY EXPERTS AND ONLY IN ACCORDANCE WITH LOCAL REQUIREMENTS AND NATIONAL ELECTRICAL CODE



**DISCONNECT THE UNIT FROM POWER SUPPLY BEFORE ANY MAINTENANCE OPERATIONS!
ENSURE THAT THE UNIT IS SWITCHED OFF FROM THE SUPPLY MAINS BEFORE REMOVING THE GUARD.**



FOLLOWING THE REGULATIONS STIPULATED HEREIN WILL ENSURE A LONG AND TROUBLE-FREE OPERATION OF THE UNIT



USER'S WARRANTY CLAIMS SHALL BE SUBJECT TO REVIEW ONLY UPON PRESENTATION OF THE UNIT, THE PAYMENT DOCUMENT AND THE USER'S MANUAL WITH THE PURCHASE DATE STAMP

WARNING - TO REDUCE THE RISK OF FIRE, ELECTRIC SHOCK, OR INJURY TO PERSONS, OBSERVE THE FOLLOWING:

-USE THIS UNIT ONLY IN THE MANNER INTENDED BY THE MANUFACTURER. IF YOU HAVE QUESTIONS, CONTACT THE MANUFACTURER.



-BEFORE SERVICING OR CLEANING UNIT, SWITCH POWER OFF AT SERVICE PANEL AND LOCK THE SERVICE DISCONNECTIN MEANS TO PEVENT POWER FROM BEING SWITCHED ON ACCIDENTALY. WHEN THE SERVICE DISCONNECTING MEANS CANNOT BE LOCKED, SECURELY FASTEN A PROMINENT WARNING DEVICE, SUCH AS A TAG, TO THE SERVICE PANEL



FOR GENERAL VENTILATING USE ONLY. DO NOT USE TO EXHAUST HAZARDOUS OR EXPLOSIVE MATERIALS AND VAPORS.

PURPOSE

CAUTION!

FOR GENERAL VENTILATING USE ONLY.

DO NOT USE TO EXHAUST HAZARDOUS OR EXPLOSIVE MATERIALS AND VAPORS AS WELL AS FLAMMABLE MIXTURES, EVAPORATION OF CHEMICALS, STICKY SUBSTANCES, FIBROUS MATERIALS, COARSE DUST, SOOT AND OIL PARTICLES OR ENVIRONMENTS FAVOURABLE FOR THE FORMATION OF HAZARDOUS SUBSTANCES (TOXIC SUBSTANCES, DUST, PATHOGENIC GERMS).



**FOR USE IN NON FIRE RATED INSTALLATIONS ONLY.
FOR USE IN ONE- AND TWO-FAMILY DWELLINGS ONLY.**

ATTENTION!

**THE AIRLITE ERV/HRV 5/8/13/17/25 US NOT FOR OUTDOOR USE!
THE THE AIRLITE ERV/HRV 5/8/13/17/25 /O CAN BE INSTALLED OUTDOORS.**



The unit is designed to ensure continuous mechanical air exchange in houses, offices, hotels, cafes, conference halls, and other utility and public spaces as well as to recover the heat energy contained in the air extracted from the premises to warm up the filtered stream of intake air.

The unit is not intended for organizing ventilation in swimming pools, saunas, greenhouses, summer gardens, and other spaces with high humidity.

Due to the ability to save heating energy by means of energy recovery, the unit is an important element of energy-efficient premises.

The unit is a component part and is not designed for stand-alone operation.

It is for fixed installation and rated for continuous operation.

DELIVERY SET

Name	Number
Air handling unit	1 pc.
User's manual	1 pc.
Packing box	1 pc.

TECHNICAL DATA

The unit is designed for application with the ambient temperature ranging from +34 °F up to +104 °F and relative humidity up to 80 %. In order to prevent condensation on the internal walls of the unit, it is necessary that the surface temperature of the casing is 2-3 °F above the dew point temperature of the transported air.

The unit design is constantly being improved, thus some models may be slightly different from those described in this manual.

OVERALL DIMENSIONS

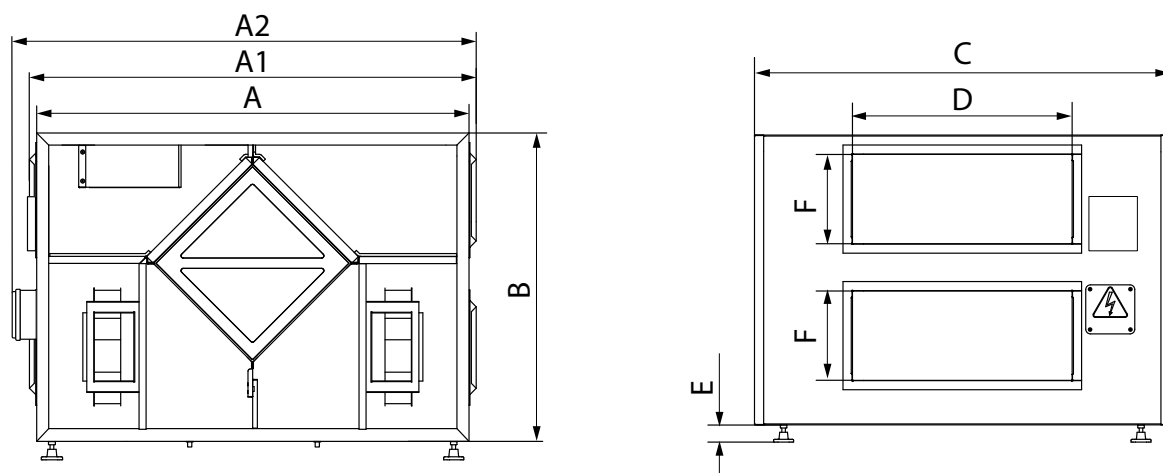

Model	Dimensions, inch								
	A	A1	A2	B	C	D	E	F	G
BLAULITE HRV/ERV 5	36 1/2	38 1/2	40	26	25 1/2	14	4	8	2 1/8
BLAULITE HRV/ERV 8									
BLAULITE HRV/ERV 13					37 1/4	20			
BLAULITE HRV/ERV 17									
BLAULITE HRV/ERV 25					49	30			

DESIGN AND OPERATING PRINCIPLE

The unit has the following operating principle: the air from the room enters the unit and is cleaned by the extract filter. Then the air is moved through the heat/energy recovery core and is exhausted outside with the extract fan. Air from outside flows into the unit, where it is cleaned by the supply filter. Then the air flows through the heat/energy recovery core and is directed to the room with the supply fan. Heat energy of warm extract air is transferred to clean intake fresh air from the outside and warms it up. The air flows are fully separated while flowing through the heat/energy recovery core. Heat recovery minimizes heat losses, which reduces the cost of space heating in the cold season.

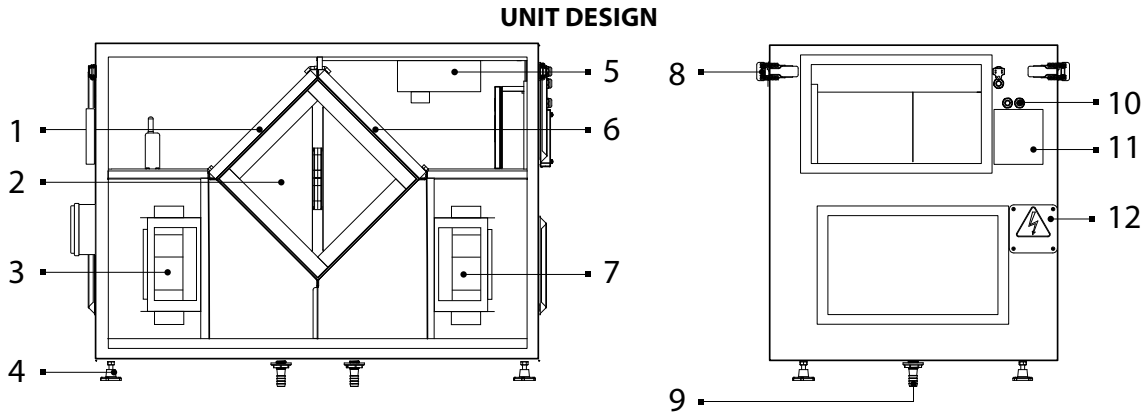

- 1 – supply filter
- 2 – counter-flow heat/energy recovery core
- 3 – extract fan (the BLAULITE HRV/ERV 13/17 unit is equipped with two fans and the BLAULITE HRV/ERV 25 unit – with three fans)
- 4 – adjustable feet
- 5 – controller unit
- 6 – extract filter
- 7 – supply fan (the BLAULITE HRV/ERV 13/17 unit is equipped with two fans, the BLAULITE HRV/ERV 25 – with three fans)
- 8 – service panel latches
- 9 – drain pipe
- 10 – cable glands
- 11 – cover of control unit and terminal block for connection of external devices
- 12 – terminal box for power supply connection

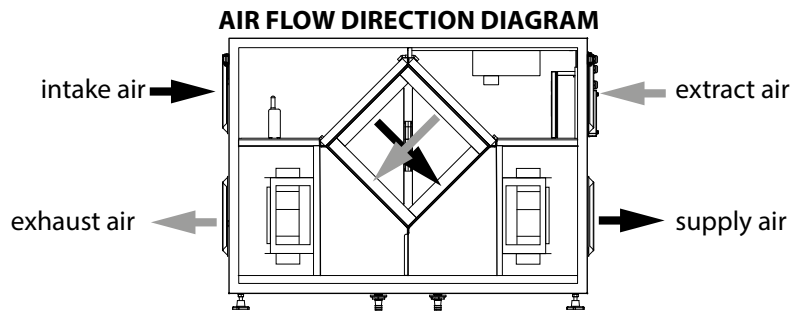

The duct connection is indicated by the corresponding labels on the unit casing.

The unit is equipped with removable hinged service panels for repair and maintenance operations. When removing the service panel, disconnect the grounding cable.

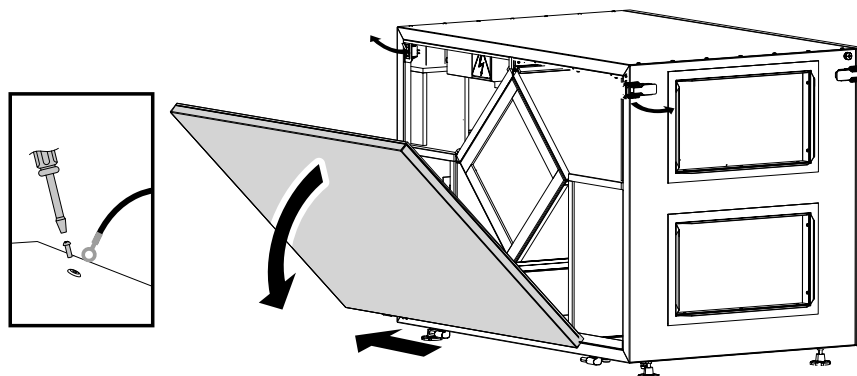

WARNING! When installing the service panel, make sure to connect a grounding cable!

Unit installation is possible both on the left and on the right.

The unit is equipped with fuses that switch off the fans when the service panel is opened.

MOUNTING AND SET-UP

When choosing the unit installation location, it is necessary to provide free access to one of the service panels for technical and service maintenance.

The unit must be mounted strictly horizontally in the longitudinal and transverse planes. Failure to do so will cause the casing distortion and may prevent proper operation.

Unit floor mounting

Install the unit on the pre-mounted floor supports, minimum 6" height to ensure sufficient access for condensate drain system installation. The horizontal position can be adjusted with the help of adjustable feet. Feet adjustment range is 9/16".

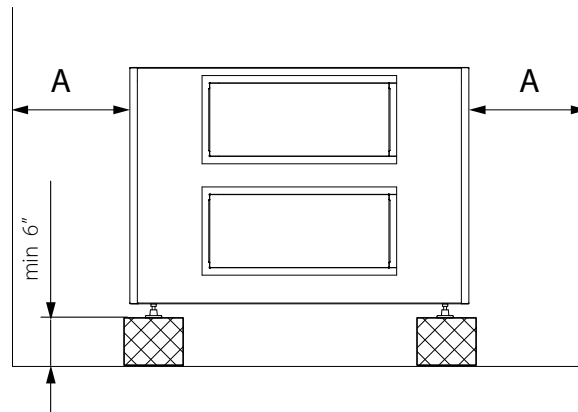

	A
BLAULITE HRV/ERV 5/8	29"
BLAULITE HRV/ERV 13/17	41"
BLAULITE HRV/ERV 25	53"

Unit suspended mounting

When choosing the unit installation location, it is necessary to provide free access to one of the service panels for technical and service maintenance.

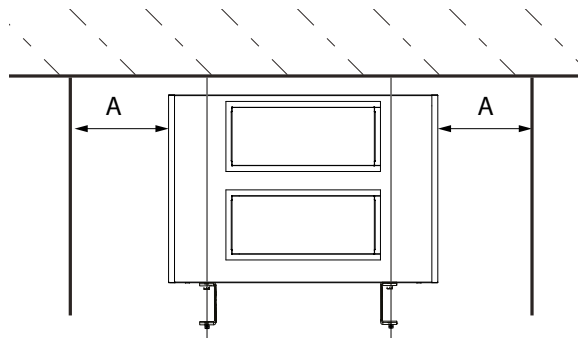

	A
BLAULITE HRV/ERV 5/8	29"
BLAULITE HRV/ERV 13/17	41"
BLAULITE HRV/ERV 25	53"

Unscrew the feet from the unit.

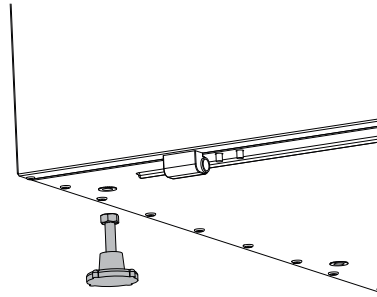

Screw the mounting beams.

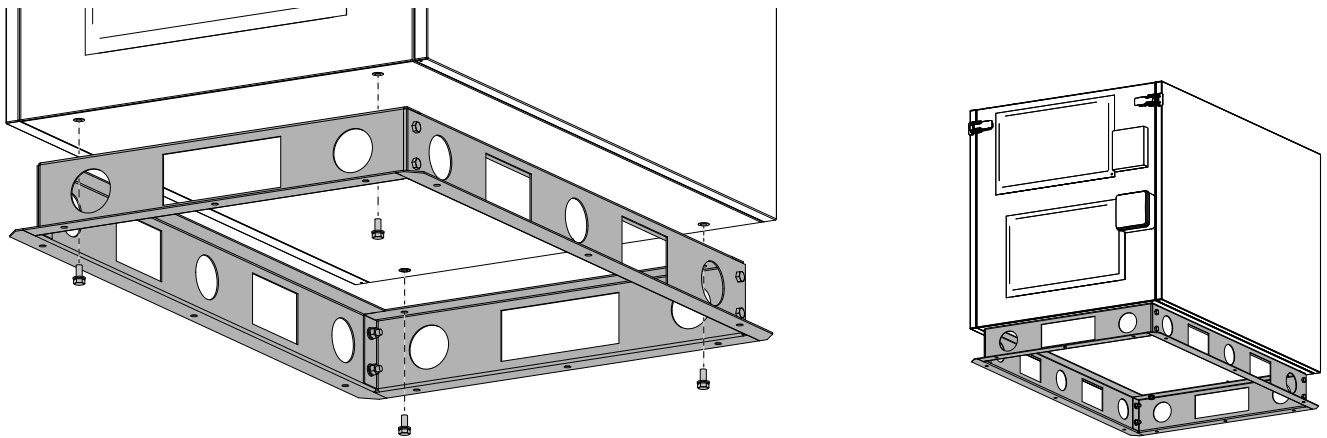

Mark the holes for the fasteners on the ceiling according to the dimensions below.

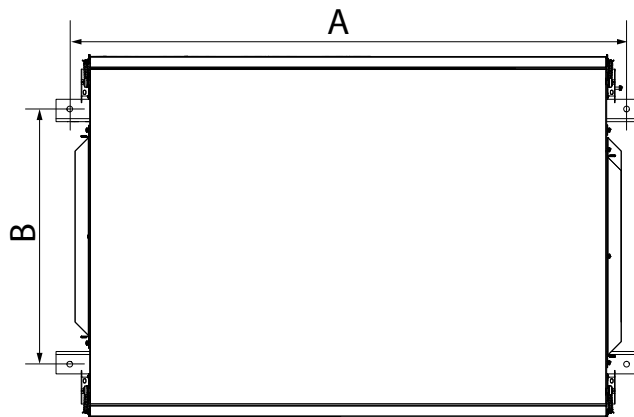

Model	Dimensions, inch	
	A	B
BLAULITE HRV/ERV 5	39 ³ / ₁₆ "	17 ¹⁵ / ₁₆ "
BLAULITE HRV/ERV 8		29 ¹⁵ / ₁₆ "
BLAULITE HRV/ERV 13		
BLAULITE HRV/ERV 17	38 ³ / ₈ "	40 ¹⁵ / ₁₆ "
BLAULITE HRV/ERV 25		

Make holes in the ceiling and fasten the threaded rods

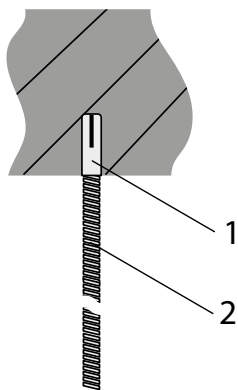

1 — anchor bushing; 2 — threaded rod

Hang the unit on the threaded rods and fix it according to the diagram

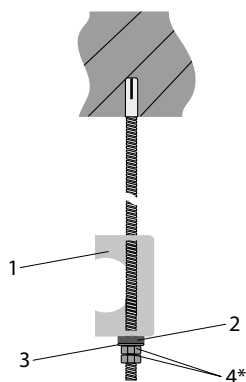

1 – mounting beam; 2 – vibration isolation washer; 3 – washer; 4 – nut (two nuts must be used)

Fasteners for mounting the unit are not included in the delivery set and must be purchased separately. The mounting surface material and the weight of the unit must be taken into account when selecting the fasteners (see technical data). Fasteners should be selected by an expert of the Installation Company.

The roof of the BLAULITE /O units which have been delivered in sections must be mounted only after joining the sections. All the roof joints must be insulated with a joint filler on the inside. Treat the screws with a sealant prior to screwing in to enable good sealing of the joints.

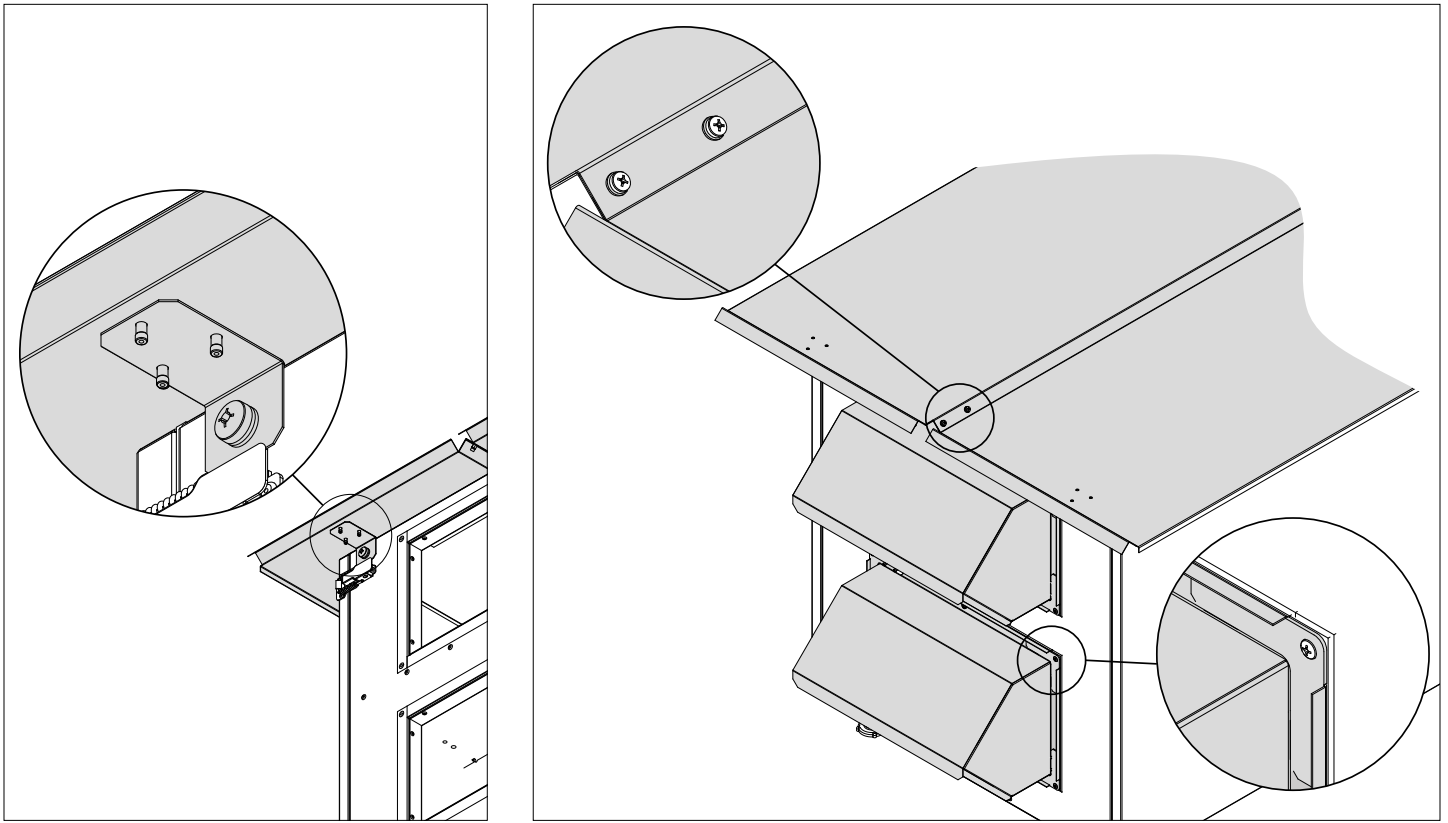

CONDENSATE DRAINAGE

The units must be connected to a condensate drain system.
 The holes for the drain pipes are at the bottom of the unit.
 Open the service panel and remove the bungs from the drain holes.
 Install the supplied drain pipes into the holes, then connect the SFK 20x32 U-trap (not included in the delivery set).
 Each drain pipe must be connected to a separate U-trap.
 The pipe slope downwards must be at least 3°.

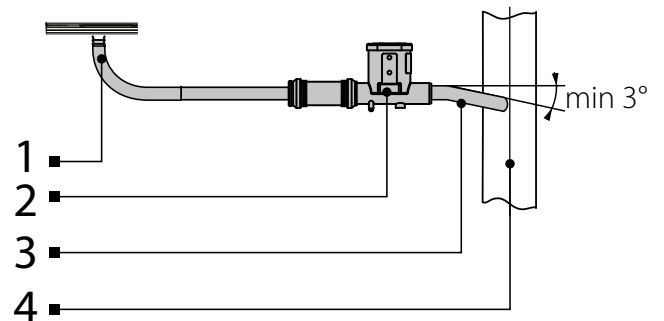
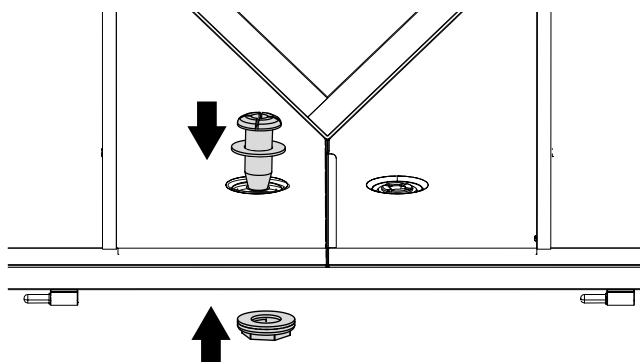

1 — drain pipe; 2 — U-trap; 3 — connecting pipe; 4 — sewage system.

CONNECTION TO POWER MAINS

The air-handling unit is for connection to the fixed installation and rated for connection to single-phase AC 120 V/60 Hz power mains. Connect the unit to power mains through the external automatic circuit breaker with a magnetic trip integrated into the fixed wiring system.

The trip current of the circuit breaker is selected based on power supply parameters of the unit, listed in the "Technical data".

The external switch location must ensure free access for quick shutdown of the unit.

The unit is equipped with fuses 5.0A (glass 5x20) and 0.315A (glass 5x20) for overload protection. In case of an overload or a short circuit the fuse blows. The fuses are located in the body of the controller unit.

Use a double pole automatic circuit breaker of the protection type C.

	Rated current of the automatic circuit breaker must not exceed
BLAULITE HRV/ERV 5/8	10 A
BLAULITE HRV/ERV 13/17	16 A
BLAULITE HRV/ERV 25	20 A

Specifications of the wires for connection must be selected from the table below.

	Power supply connection (cable type, cross section min/max)	External devices connection (cable type, cross section min/max)
BLAULITE HRV/ERV 5/8	Flexible, AWG20/AWG18	Flexible, AWG20/AWG18
BLAULITE HRV/ERV 13/17	Flexible, AWG14/AWG12	
BLAULITE HRV/ERV 25	Flexible, AWG14/AWG12	

Fixed installation according local installation rules.

WARNING! SHOULD BE CONNECTED THROUGH SWITCH, BUILT INTO THE FIXED WIRING!

To connect the power cable, perform the following steps:

- Remove the service panel

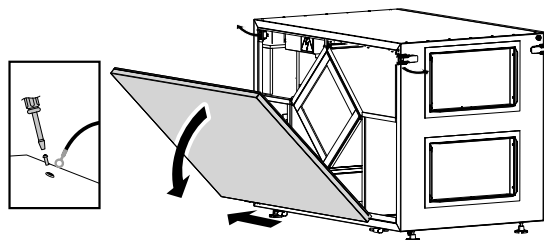

WARNING! WHEN INSTALLING THE SERVICE PANEL, MAKE SURE TO CONNECT A GROUNDING CABLE!

- Remove the filter and the heat exchanger

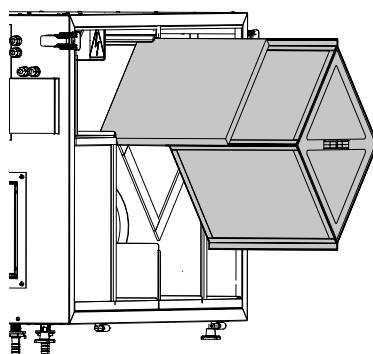

- Lead the power cable through the cable gland

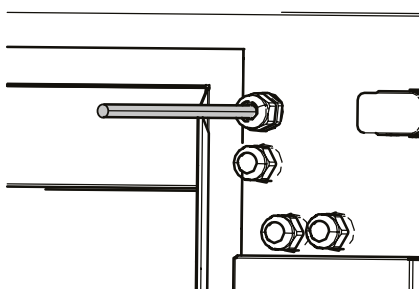

- Unscrew the two screws securing the controller unit cover

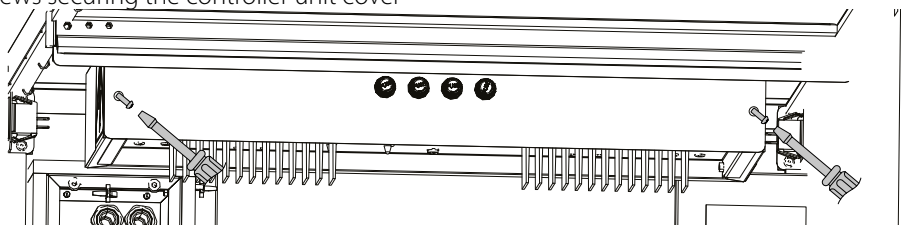

- Open the cover of the controller unit

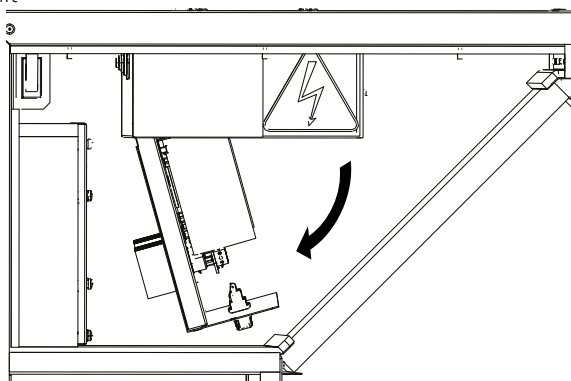

- Lead the power cable through the clip into the controller unit and connect it to the terminal block according to the wiring diagram

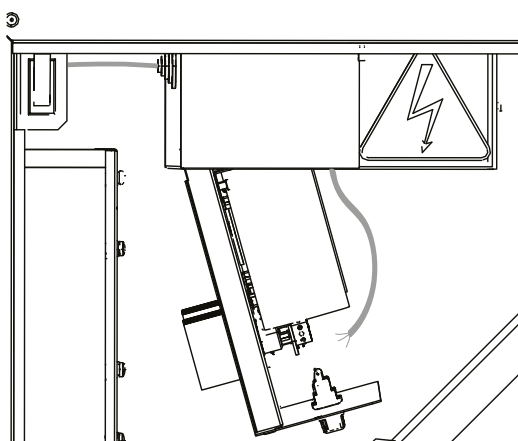

The unit is equipped with fuses for overload protection. In case of an overload or a short circuit the fuse blows. The fuses are located in the body of the controller unit.

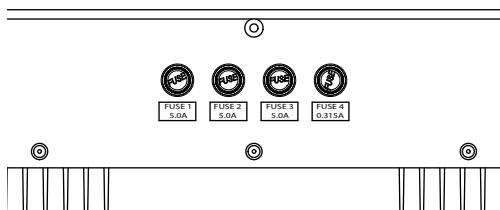

To replace the fuse, disconnect the unit from power supply, replace the fuse and check the unit for proper operation. Install only fuses with the rated current indicated on the label. If the fuse blows again, contact the Seller.

WIRING DIAGRAM

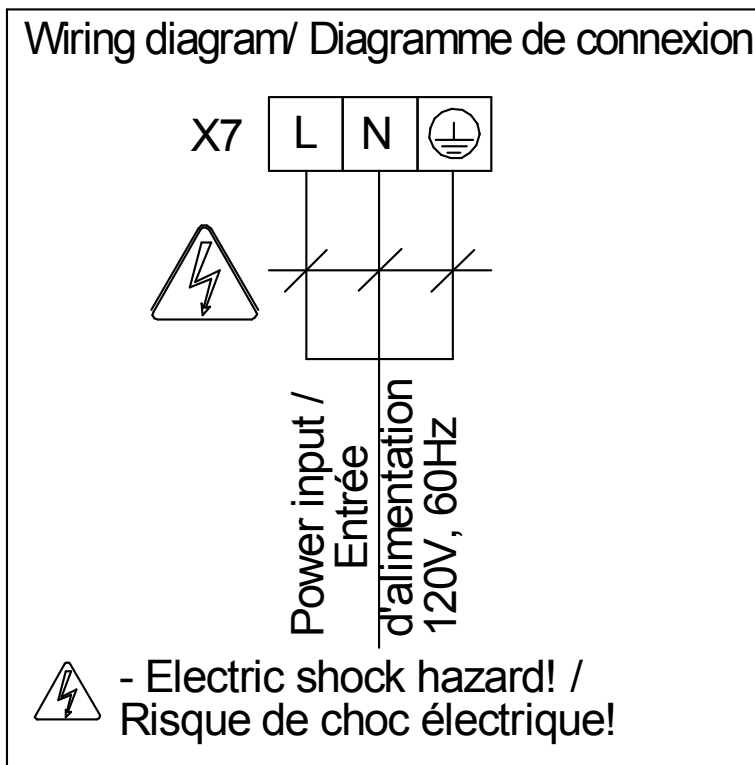
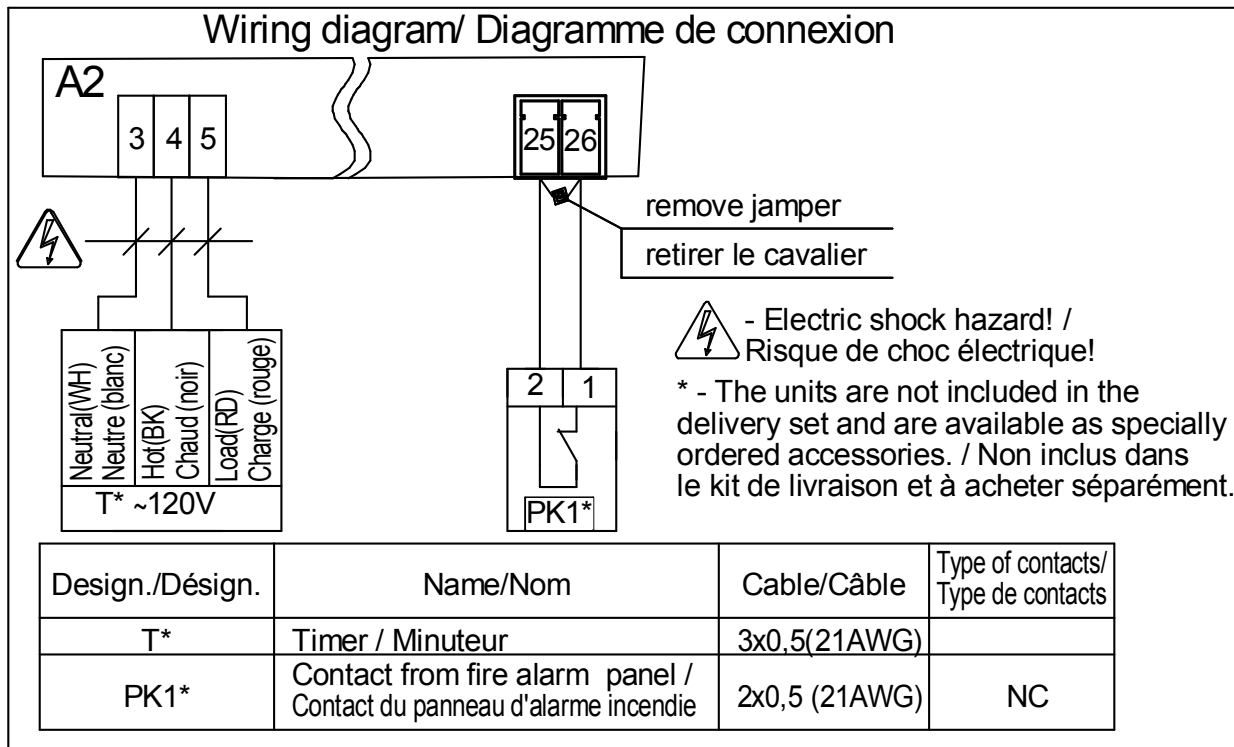

CONNECTION OF EXTERNAL CONTROL DEVICES

Up to 5 external control devices can be connected to the unit. In case of activation of any connected control, the unit switches to high speed.

The following control devices can be connected to the unit:

1. Remote control panel (thermostat)

The remote control panel (thermostat) provides:

- Switching the unit ON/OFF
- Speed switching
- Room temperature indication
- Scheduled operation

2. Carbometer (CO₂)

The carbometer (CO₂) is designed for offices, houses and other public places. It provides switching to high-speed ventilation when the carbon dioxide level exceeds the selected value.

3. Humidistat

The humidistat is used for humidity level control in the room. If the humidity exceeds the set level, the humidistat will switch the unit to high-speed ventilation mode. The unit will operate in high-speed ventilation mode until the relative humidity drops below the setpoint on the humidistat. If necessary, the humidity level can be adjusted.

4. Timer

The remote timer should be installed in areas with air pollution. When the timer is switched on, the unit switches to high-speed ventilation mode for the time set on the timer.

5. ON/OFF switch

The switch must be installed in areas with air pollution. When the contacts of the ON/OFF switch are closed, the unit switches to a high speed ventilation mode. Open the contacts of the ON/OFF switch to return to a continuous low-speed ventilation mode.

Signal from fire alarm panel

When the dry contacts of the controllers #25 and #26 open, the unit stops in emergency mode. These contacts are short-circuited by the manufacturer by means of the jumper. When used, the jumper is removed.

The external devices are powered by a 24 V AC or 24 V DC voltage, depending on the characteristics of the connected device.

Several external devices with a total current of less than 300 mA may be connected to terminals 1-4 in parallel.

All listed external devices must be connected according to the wiring diagram of the external devices.

Wiring diagram for external devices

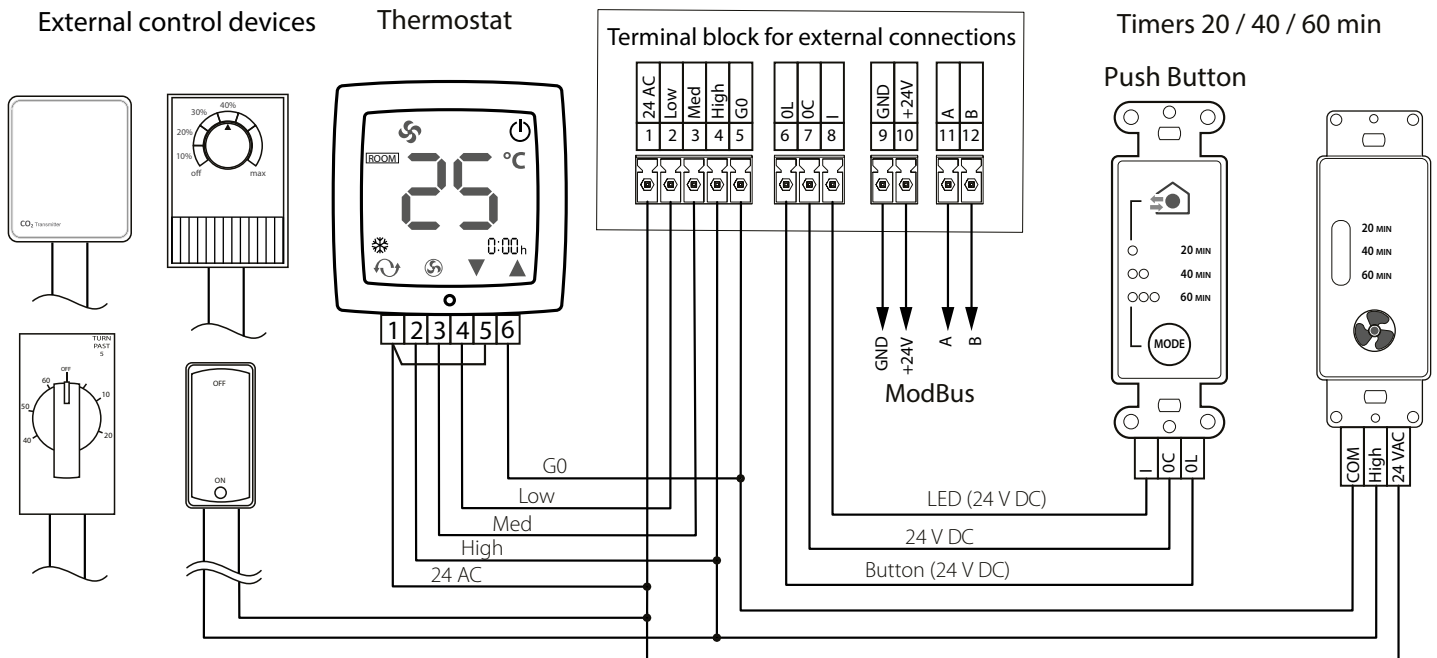

UNIT CONTROL

UNIT OPERATION MODES

- Continuous Operation or Standby mode.
- High-speed ventilation mode.

The unit is equipped with a three-position switch that allows you to select **LOW** or **MED** speed for the Continuous Operation mode or set **STANDBY** mode.

After the power is turned on, the unit starts operating in the mode selected by the three-position switch. There are connectors in the unit control compartment with the necessary unit control signals:

1. 24V AC — 24 V AC power mains
2. Low — low speed
3. Med — medium speed
4. High — high speed
5. G0 — common power supply 24 V AC
6. OL — Push Button connection (OL circuit)
7. OC — Push Button connection (OC circuit)
8. I — Push Button connection (circuit I)
9. GND — RS485 interface (shared wire)
10. + 24V — RS485 interface (power supply +24 Volts constant)
11. A — RS485 interface (line "A")
12. B — RS485 interface (line "B")

Control unit with a circuit board for external connections

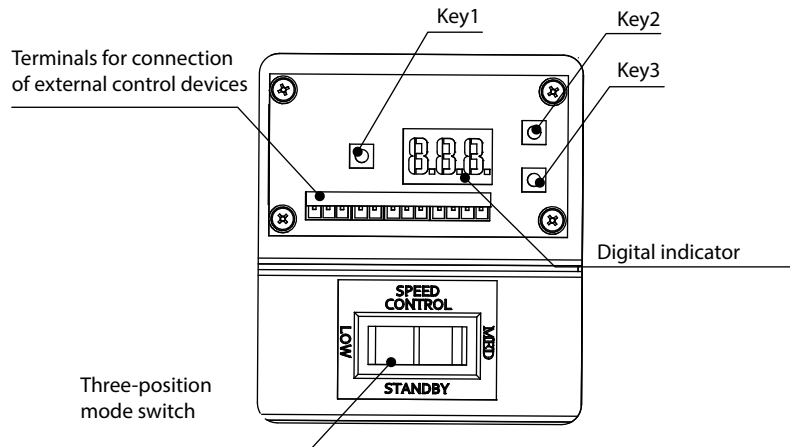

To access the control unit and the terminal block of the external control devices of the unit, remove the screws and the cover.

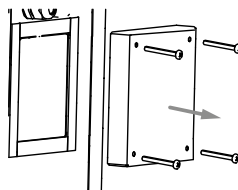

When a 24V AC signal is applied to Low, Med or High contacts, the unit switches to the corresponding speed.

If the Push Button is connected to the respective connector and the timer is activated with it, the unit will switch to a high speed regardless of the previously set speed, and will run at high speed throughout the time set by the timer.

If a remote 120 V AC timer is connected to the unit (see the wiring diagram), the unit will also switch to a high speed after the timer activation regardless of the previously set speed, and will operate at high speed for the time specified by the 120 V AC timer.

Supply and extract fan air flow can be adjusted for each fan and speed separately.

You can set airflow from 30 % to 100 %.

SPEED SETUP

The control system enables setting same speed or synchronously adjusting speed of the supply and extract fans (see **ALL**) for each selected speed.

In case when the resistance of the supply and exhaust lines is not the same, the speed of the supply and extract fan can be individually adjusted and this setting will be saved in the controller memory (see **SPL** and **Eht**, respectively).

The controller circuit board has a digital indicator and "**KEY1**", "**KEY2**", and "**KEY3**" buttons which are used for operation mode setup and editing of the operation parameters.

After switching on power the ventilation unit operates norm **ALL** y and the light indicator is off.

Press "**KEY1**" to open the Settings menu.

Select the required menu item using the buttons "**KEY2**" and "**KEY3**".

- "**ALL**": current air flow of both the supply and the extract fans with a range from 30 % to 100 % (displayed by the previously set value for the supply fan operation for the selected speed). For example, when the low speed ("**LOW**") is turned on, changing this parameter will change the low speed of the supply and extract fans simultaneously. To view or change this parameter, press the "**KEY1**" button, use the "**KEY2**", "**KEY3**" buttons to set the required value. Press the "**KEY1**" button to save the value in the non-volatile memory and return to the Settings menu.
- "**SPL**": current supply fan speed value with a range from 30 % to 100 %. For example, if the medium speed ("**MED**") is turned on, changing this parameter will change the medium speed of the supply fan. To view or change this parameter, press the "**KEY1**" button and set the required value using the "**KEY2**" and "**KEY3**" buttons. Press the "**KEY1**" button to save the value in the non-volatile memory and return to the Settings menu.
- "**Eht**": current extract fan speed with a range from 30 % to 100 %. For example, if the high speed ("**HIGH**") is turned on, changing this parameter will change the high speed of the extract fan. To view or change this parameter, press the "**KEY1**" button and set the required value using the "**KEY2**" and "**KEY3**" buttons. Press the "**KEY1**" button to save the value in the non-volatile memory and return to the Settings menu.
- "**def**": reset to the factory settings (default settings). To reset to the factory settings, press "**KEY1**", then select "-Y-" using the "**KEY2**" and "**KEY3**" buttons and press the "**KEY1**" button. In case of cancellation using the "**KEY2**" and "**KEY3**" buttons, select the "-n-" value and press "**KEY1**".
- "**Cor**": correction of the temperature sensor. To correct the temperature value communicated by the temperature sensor, press the "**KEY1**" button and change the value using the "**KEY2**" and "**KEY3**" buttons, then press the "**KEY1**" button.
- "**Prg**": software version. Press the "**KEY1**" button to view the software version.

In case of alarm, the alarm message "Err" is displayed. Press the "**KEY1**" button to view the alarm codes. To do this, press "**KEY2**" and "**KEY3**" to scroll through the list of possible alarms:

- "**1-Y**": fire alarm activation or, if it is not connected, - the jumper between the contacts 25-26 of the controller is missing.
- "**2-Y**": temperature sensor short circuit.
- "**3-Y**": temperature sensor breakout.

If there is no alarm in the list, the symbol -n will be displayed next to the corresponding number, namely: "**1-n**", "**2-n**", "**3-n**".

FREEZE PROTECTION FUNCTION

The freeze protection function prevents the heat recovery core from freezing in the cold season. This function is activated automatically and cannot be turned on or off. Operation principle of the freeze protection function: depending on the temperature detected by the outdoor air sensor installed upstream of the heat recovery core, the unit periodically switches between the normal operation and the special defrost mode (the extract fan runs at high speed, the supply fan is off).

The temperature conditions for this mode are described in the table below.

Air temperature detected by the sensor in the supply air stream downstream of the heat recovery core	Duration of the operation in the respective mode [min]	
	Defrosting mode	Normal operation
Above 23 °F	-	permanent
From 5 °F up to 23 °F	10	30
From -17 °F up to 5 °F	10	20
Below -17 °F	10	15

TECHNICAL MAINTENANCE

Maintenance operations of the unit are required 3-4 times per year.

Maintenance includes general cleaning of the unit and the following operations:

1. Filter maintenance.

Dirty filters increase air resistance in the system and reduce supply air volume.

The filters require cleaning not less than 3-4 times per year.



WARNING – TO REDUCE THE RISK OF FIRE, ELECTRIC SHOCK, OR INJURY TO PERSONS, OBSERVE THE FOLLOWING:

- **BEFORE REMOVING THE FILTERS, SWITCH OFF THE EXTERNAL AUTOMATIC CIRCUIT BREAKER AND LOCK THE SERVICE DISCONNECTING MEANS, THEN OPEN THE HINGED SERVICE PANEL AND REMOVE THE FILTERS CAREFULLY.**
- **IT IS POSSIBLE TO CLEAN FILTERS WITH A VACUUM CLEANER OR RINSE THEM WITH WATER AND DRY. MAKE SURE FILTERS ARE COMPLETELY DRY BEFORE THEY HAVE BEEN INSTALLED BACK INTO THE UNIT.**

After cleaning install the filters in the reverse order.

Filters can be cleaned several times before mechanical wear.

For new filters contact the Seller.

2. Heat/energy recovery core maintenance (once per year).

Some dust may accumulate on the heat/energy recovery core even in case of regular maintenance of the filters.

To maintain the high heat recovery efficiency, regular cleaning is required.

To clean the heat exchanger, remove it from the unit and clean the heat exchanger by using compressed air or a vacuum cleaner. You can also rinse the heat exchanger with a warm detergent solution and dry it.

Before removing the heat exchanger, disconnect the unit from the power supply, then open the hinged service panel and remove the heat exchanger by pulling it towards you.

After cleaning, install the dry heat exchanger in the reverse order.

3. Fan maintenance (once per year).

Even in case of regular maintenance of the filters, some dust may accumulate inside the fans and reduce the fan performance and supply air flow.

Clean the fans with a soft cloth, brush, or using compressed air.

Do not use water, aggressive solvents, or sharp objects as they may damage the impeller.

4. Supply air flow control (twice per year).

The supply duct grille may get clogged with leaves and other objects reducing the unit performance and supply air delivery.

Check the supply grille twice per year and clean it as required.

5. Ductwork system maintenance (once in 5 years).

Even regular fulfilling of all the maintenance operations prescribed above may not completely prevent dirt accumulation in the air ducts, which leads to air pollution and reduces the unit capacity.

Duct maintenance means regular cleaning or replacement.

TROUBLESHOOTING

Problem	Possible reasons	Troubleshooting
The fan(s) does not start when the unit is on.	No power supply.	Make sure the power supply line is connected correctly, otherwise troubleshoot a connection error.
	The motor is jammed, the impeller blades are soiled.	Turn the unit off. Troubleshoot the motor jam and the impeller clogging. Clean the blades. Restart the unit.
The unit does not turn on, Err is constantly lit on the indicator.	Alarm in the system.	Contact the Seller.
Automatic circuit breaker trips following the unit turning on.	Overcurrent as a result of short circuit in the electric line.	Turn the unit off. Contact the Seller.
Low air flow.	Low set fan speed.	Set higher speed.
	The filters and the fans are clogged, the heat exchanger is clogged.	Clean or replace the filters, clean the fans, and the heat exchanger.
	Ventilation system elements (air ducts, diffusers, louver shutters, grilles) are clogged, damaged or closed.	Clean or replace the ventilation system elements, such as air ducts, diffusers, louver shutters, grilles.
Cold supply air.	The extract filter is soiled.	Clean or replace the extract filter.
Noise, vibration.	The impeller(s) is soiled.	Clean the impeller(s).
	The fan or casing screw connection is loose.	Tighten the screw connection of the fans or the casing all the way.
	No anti-vibration connectors on air duct pipe flanges.	Install anti-vibration connectors.
Water leakage (only for the HRV units)	The drainage system is soiled, damaged or arranged not correctly.	Clean the drain line. Check the drain line slope angle. Make sure that the U-trap is filled with water and the drain pipes are frost protected.

STORAGE AND TRANSPORTATION REGULATIONS

- Store the unit in the manufacturer’s original packaging box in a dry closed ventilated premise with temperature range +41 °F...+104 °F and relative humidity up to 70 %.
- Storage environment must not contain aggressive vapors and chemical mixtures provoking corrosion, insulation, and sealing deformation.
- Use suitable hoist machinery for handling and storage operations to prevent possible damage to the unit.
- Follow the handling requirements applicable for the particular type of cargo.
- The unit can be carried in the original packaging by any mode of transport provided proper protection against precipitation and mechanical damage. The unit must be transported only in the working position.
- Avoid sharp blows, scratches, or rough handling during loading and unloading.
- Prior to the initial power-up after transportation at low temperatures, allow the unit to warm up at operating temperature for at least 3-4 hours.

MANUFACTURER'S WARRANTY

Production meets standard operating requirements in the USA and Canada.

Blauberg warrants to the original purchaser of the unit that it will be free from defects in materials or workmanship for a period of 24 months from the date of original purchase. The Blauberg warrants to the original purchaser of the unit that the integrated control unit will be free from defects in materials and workmanship for a period of 24 months from the date of original purchase.

THERE ARE NO OTHER WARRANTIES, EXPRESS OR IMPLIED, INCLUDING, BUT NOT LIMITED TO, IMPLIED WARRANTIES OF MERCHANTABILITY OR FITNESS FOR A PARTICULAR PURPOSE.

During the stated warranty period, Blauberg will, at its option, repair or replace, without charge, any product or part which is found to be defective under normal use and service. This warranty does not cover (a) normal maintenance and normal service or (b) any products or parts which have been subject to misuse, negligence, accident, improper maintenance or repair (other than by Blauberg), faulty installation or installation contrary to recommended installation instructions. Labor to remove and replace products is not covered. The duration of any implied warranty is limited to the time period specified for the express warranty. Some states do not allow limitations on how long an implied warranty lasts, so the above limitation may not apply to you.

BLAUBERG OBLIGATION TO REPAIR OR REPLACE, AT BLAUBERG OPTION, SHALL BE THE PURCHASER'S SOLE AND EXCLUSIVE REMEDY UNDER THIS WARRANTY. BLAUBERG SHALL NOT BE LIABLE FOR INCIDENTAL, CONSEQUENTIAL OR SPECIAL DAMAGES ARISING OUT OF OR IN CONNECTION WITH PRODUCT USE OR PERFORMANCE.

Some states do not allow the exclusion or limitations of incidental or consequential damages, so the above limitation or exclusion may not apply to you. This warranty gives you specific legal rights, and you may also have other rights which vary from state to state. This warranty supersedes all prior warranties. If proof of sales date is absent, warranty period is calculated from the production date. The unit can be exchanged at the following address:

Blauberg North America LLC
1501 Veterans Memorial Pkwy E, Ste. 202, Lafayette, IN 47905
Tel: (765) 780-7139
Fax: (661) 825-8895
info@blauberg-na.com

Please follow guidelines in this manual for product problem-free operation.

CERTIFICATE OF ACCEPTANCE

Unit Type	Air handling unit
Model	
Serial Number	
Manufacture Date	
Quality Inspector's Stamp	

SELLER INFORMATION

Seller	
Address	
Phone Number	
E-mail	
Purchase Date	
This is to certify acceptance of the complete unit delivery with the user's manual. The warranty terms are acknowledged and accepted.	
Customer's Signature	

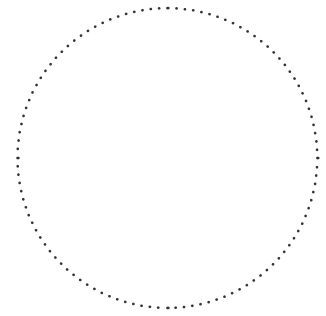

Seller's Stamp

INSTALLATION CERTIFICATE

The _____ unit is installed pursuant to the requirements stated in the present user's manual.	
Company name	
Address	
Phone Number	
Installation Technician's Full Name	
Installation Date:	Signature:
The unit has been installed in accordance with the provisions of all the applicable local and national construction, electrical and technical codes and standards. The unit operates normally as intended by the manufacturer.	
Signature:	

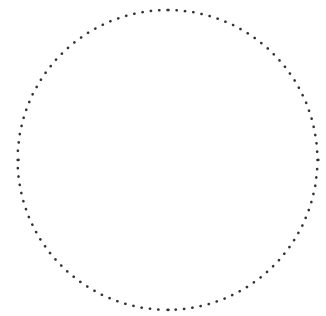

Installation Stamp

WARRANTY CARD

Unit Type	Air handling unit
Model	
Serial Number	
Manufacture Date	
Purchase Date	
Warranty Period	
Seller	

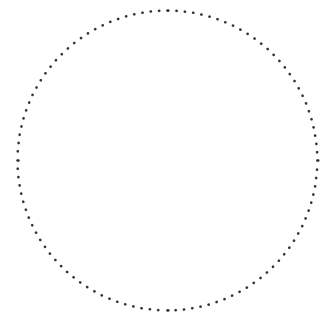

Seller's Stamp

