

# ERV EC DR 150

## Energy Recovery Ventilator

**ERV EC DR 150** is a complete whole house ventilation system designed to bring a continuous supply of fresh air into the house while exhausting an equal amount of stale air.  
Five year warranty.



### Casing

- Steel casing is covered with high-quality multilayer aluminum and zinc alloy to prevent corrosion.
- The casing is equipped with a switch to turn the ventilator off when the service panel is opened.

### Filter

- Washable MERV 6 air filters in exhaust and supply air streams.
- Optional supply: anti grease aluminum filter.

### Fans

- High efficient electronically commutated motors with external motor and impeller with backward curved blades. EC motors are featured with high performance and total speed controllable range. The electric motors and impellers are dynamically balanced.

### Energy Recovery Core

- Enthalpic core provides both heat&humidity recovery. For enthalpic core no drain required.



### Defrost System

- Recirculation or only exhaust defrost modes are available.

### Suitable for

- Bathroom / kitchen / apartments / cottages / small offices.

### Constant Flow

- ERV EC DR 150 CF** has an automatic constant air flow control function to keep the air flow in supply and exhaust air ducts constant even in case of variable air resistance.
- This function is provided with the integrated air flow control units. The electronic sensors convert the actual air flow to the analogue signal that is proportional to the air flow in the air duct. These signals are transmitted to the controller that controls the rotation speed of a respective fan in such a way that the actual rotations speed is equal to the set value.

### Manual Balancing

- Manual balancing is a standard balancing system. Fan speed manually adjusted by operating on units controller (built-in control board with independent fan speed adjustment 0 %-100 %).

### Control Board

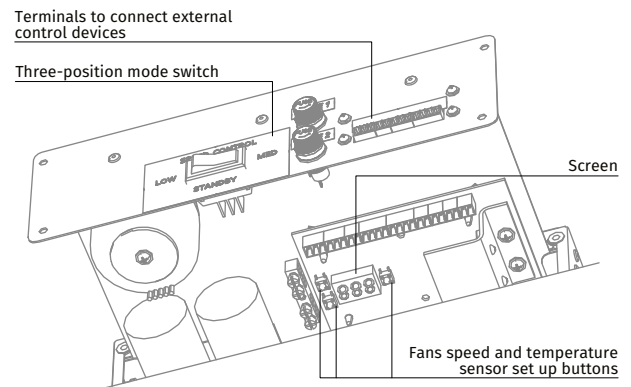

- The unit incorporates an integrated control system with following functions:
  - Operation mode switch.
  - Air flow balancing enabled by supply and exhaust fan independent speed adjustment from 0 to 100 % (percentage is displayed on built-in screen).
  - Automatic recovery core frost protection.
  - External control device connection (up to 5 at the same time).

MODEL	QUANTITY	COMMENTS	PROJECT
			location:
			architect:
			engineer:
			contractor:
			submitted by:

**Dimensions**

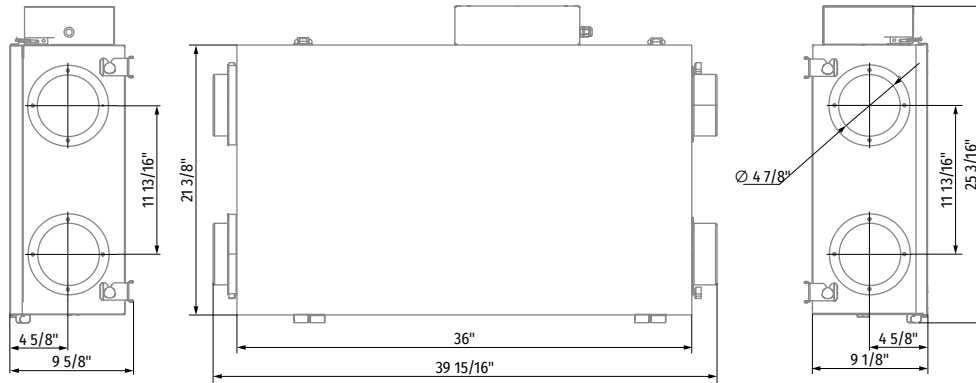

**Technical Data**

External Static Pressure		Net Supply Air Flow		Gross Air Flow				Power
Pa	in WG	l/s	CFM	Supply	Exhaust	Supply	Exhaust	
25	0.1	85	181	88	186	81	171	186
50	0.2	82	175	85	180	78	165	186
75	0.3	80	169	82	174	75	159	186
100	0.4	77	162	79	167	72	153	185
125	0.5	74	156	76	161	70	147	185
150	0.6	70	149	73	154	67	141	184
175	0.7	67	142	69	146	64	135	184
200	0.8	64	135	66	139	61	128	184
225	0.9	55	117	62	131	57	121	183
250	1	52	110	58	123	54	114	182
275	1.1	49	104	54	115	51	107	181

External Static Pressure		Net Supply Air Flow		Gross Air Flow				Power
Pa	in WG	l/s	CFM	Supply	Exhaust	Supply	Exhaust	
300	1.2	45	96	50	107	47	99	181
325	1.3	42	88	46	97	43	91	180
350	1.4	38	80	41	88	39	83	178
375	1.5	34	73	37	78	36	75	176
400	1.6	30	64	32	69	31	66	174
425	1.7	26	54	28	58	27	56	172
450	1.8	21	45	22	47	22	47	169
475	1.9	16	35	17	36	17	36	166
500	2	12	24	12	25	12	25	163
525	2.1	6	14	7	14	7	14	159
550	2.2	2	4	2	3	2	4	156

Note: fan curve performed on high speed

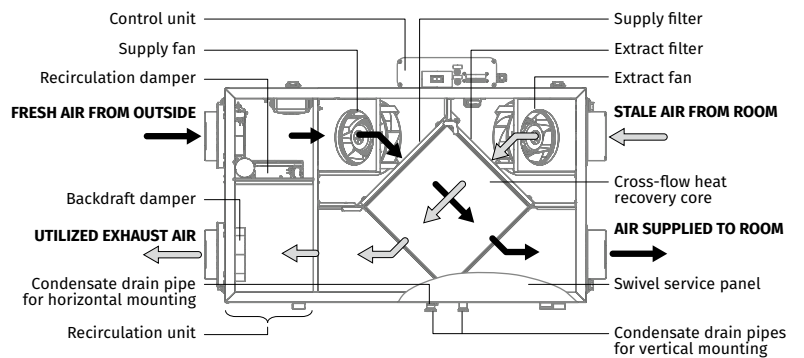
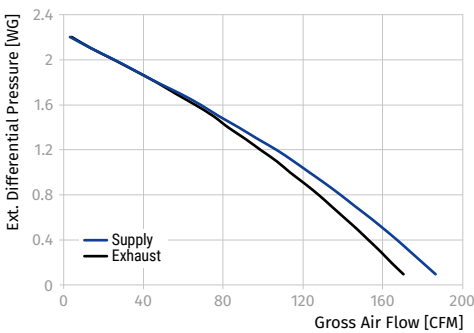

**Energy Performance**

		Supply Temperature		Net Air Flow		Average Power [Watts]	Sensible Recovery Efficiency	Apparent Sensible Effectiveness	Net Moisture Transfer
		°C	°F	l/s	CFM				
Heating	I	0	32	31	66	26	73	82	0.46
	II	0	32	46	97	42	70	78	0.38
	III	0	32	50	107	52	68	75	0.36
	IV								
	V	-25	-13	31	65	89	63	77	0.37
**Total Recovery Efficiency									
Cooling	VI	35	95	31	66	26	50.1**	68	0.42

\*\* Indicates total recovery efficiency, not sensible recovery efficiency 250 Pa = 1 in of water: 0.472 l/s = 1 CFM

Model	Volts	Max. Watts	Max. Amps
ERV EC DR 150	120 V, 60 Hz	186	2.5