

# FRESHBOX 100 WiFi

## Single-Room Heat Recovery Ventilators



### Description

- o Efficient solution for supply and exhaust ventilation of enclosed spaces.
- o Low-energy EC fans.
- o Silent operation.
- o Upgradeable with an exhaust duct to provide air extraction from the bathroom.
- o Easy installation.
- o Compact size.
- o Wi-Fi communication
- o Controlled by Android or iOS smartphone or tablet.

### Casing

- o Polymer coated metal casing decorated with an acrylic front panel. Heat and noise insulation is ensured by a layer of 3/8" cellular synthetic rubber.
- o The front panel provides convenient access for filter maintenance and has a lock for extra security.
- o The unit has two  $\varnothing 3^{15/16}$ " pipes for fresh air intake and stale air extraction outside. The third  $\varnothing 3^{15/16}$ " pipe (included in the scope of delivery) can be additionally fitted to the unit to connect the exhaust air duct from the bathroom.

### Fans

- o The units feature efficient electronically commutated (EC) motors with an external rotor and impellers with forward curved blades. These state-of-the-art motors are the most advanced solution in energy efficiency today.
- o EC motors are characterised with high performance and optimum control across the entire speed range. In addition to that the efficiency of electronically commutated motors reaches very impressive levels of up to 90 %. EC motors are featured with high performance and total speed controllable range. High efficiency reaching 90 % is the premium advantage of the electronically commutated motors.

### Air filtration

- o Supply air cleaning is provided by the MERV8 and MERV14 panel filters (PM2.5 > 75 %). To meet more stringent air purity requirements the MERV14 filter can be replaced with an HEPA Filter type C (PM2.5 > 95 %) (purchased separately). Exhaust air is cleaned by the panel filter MERV8.

### Air dampers

- o The unit is equipped with supply and exhaust air dampers which activate automatically to prevent drafts while the unit is off.

### Suitable for

- o Bathroom / kitchen / apartments / cottages / small offices

### Functioning

- o The cold outdoor air passes through the filters and the heat exchanger and then is delivered to the serviced space by the supply centrifugal fan.
- o Warm stale air from indoors passes through the filter and the heat exchanger and is discharged outdoors by the centrifugal fan.
- o The supply and exhaust air flows are fully separated which helps eliminate the possibility of odour or microbial transfer between the streams.

### Control

- o The unit is equipped with a control panel.
- o The remote control is supplied as standard.
- o Wi-Fi communication
- o Controlled by Android or iOS smartphone or tablet.

### Heat exchanger

- o The **Freshbox 100 WiFi** units are equipped with a counter-flow heat recovery core with a polystyrene core.
  - **In the cold season** the exhaust air heat is captured and transferred to the supply air stream which reduces the ventilation-generated heat losses. Some condensate may form during heat recovery. The condensate is collected in the drain pan and is removed from the exhaust air duct.
  - **In the warm season** the intake air heat is transferred to the extract air stream. This allows for a considerable reduction of the supply air temperature which, in turn, reduces the air conditioning load.

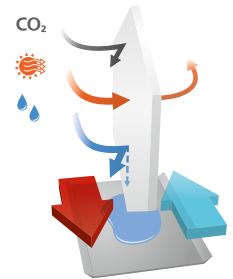

### FREEZE PROTECTION

- o Freshbox 100 WiFi features an exhaust air temperature sensor downstream of the heat exchanger which disables the supply fan to let the warm extract air warm up the heat exchanger. After that the supply fan is turned on and the unit reverts to the normal operation mode.

MODEL	QUANTITY	COMMENTS	PROJECT
			location:
			architect:
			engineer:
			contractor:
			submitted by:

### Overall dimensions [in]

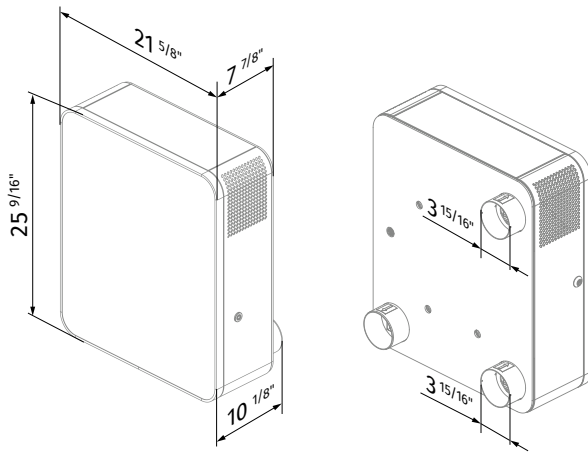

### Technical data

Parameters	Freshbox 100 WiFi		
	I	II	III
Speed			
Voltage [V / 50 (60) Hz]		1~120	
Max. power [W]	20	29	53
Max. current consumption [A]		0.4	
Maximum air flow [CFM (l/s)]	18 (8)	35 (17)	59 (28)
SFP [W/l/s]	1.44	1.26	1.62
RPM [min <sup>-1</sup> ]		max 2200	
Sound [dBA]	13	27	39
Transported air temperature [°F (°C)]		-13...+122 (-25...+50)	
Casing material		polymer coated steel	
Insulation thickness [in]		3/8"	
Extract filter		MERV8	
Supply filter		MERV8 + MERV14 (Option: MERV14 Carbon; HEPA Filter type C)	
Connected air duct diameter [in]		4"	
Weight [lb]		68.3	
Heat recovery efficiency [%]*	96	92	87
Heat recovery core type		counter-flow	
Heat recovery core material		polystyrene	
SEC class		A	

\*Heat recovery efficiency is specified in compliance with EN 13141-8.