

# VENTO EXPERT A50-1 S Pro

## Single-Room Heat Recovery Ventilator

### Description

- o Vento Expert A50-1 Pro designed to ensure filtration and supply of fresh air into the room as well as exhaust of stale air with energy regeneration. No freezing and condensation during operation.
- o Efficient supply and exhaust single-room ventilation air flow up to 30 CFM.



### Key Features

- o Unique Single Room Heat Recovery Ventilator.
- o One Vento Expert unit in ventilation mode can serve room up to 500 sq. ft.\*
- o High-tech ceramic energy regenerator with max. heat recovery efficiency up to 93 %.
- o Built-in Humidity sensor.
- o Automatic air shutters.
- o MERV 5 filters (optionally MERV 13 filter).
- o Antibacterial treatment of ERV core and filters.
- o Easy installation and maintenance.

\*In accordance with ANSI/ASHRAE Standard 62.2-2016

### Dimensions [in (mm)]

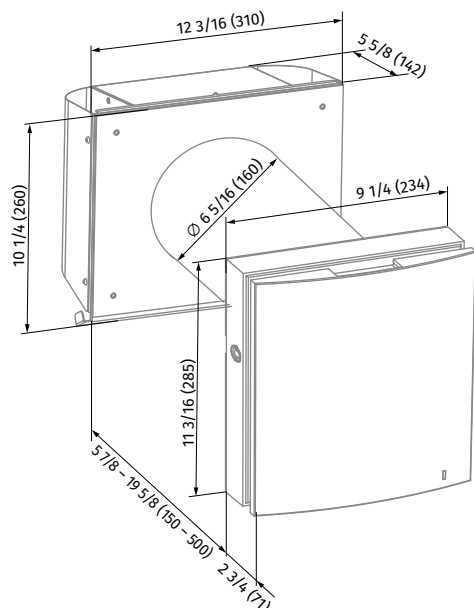

### Motor

- o Reversible fan with EC motor.

### Control

- o Control of the unit operation mode is performed by means of sensor control panel located on the unit casing or a remote controller. The unit is equipped with a humidity sensor for indoor humidity control.
- o Connection of the units in series ensures balanced ventilation. First unit in the chain becomes the master one. Ventilation mode of the entire system can be controlled by means of the control panel on the master unit. A signal from the remote control is received by the master unit only.

### Performance

Parameters	Vento Expert A50-1 S Pro		
Speed	1	2	3
Supply voltage, 50/60 Hz [V]	1~100-240		
Power [W]	3.61	4.15	5.20
Max. current consumption [A]	0.025	0.030	0.039
Air flow in ventilation mode [CFM]	9	18	30
Air flow in regeneration mode [CFM]	4	9	15
RPM	800	1300	1900
Sound [Sones]	0.6	1.0	1.2
Noise attenuation according to DIN EN ISO 10140-2: 2010 [Sones]	2.5		
Indoor/outdoor airtightness classification of the complete unit in accordance with EN 13141-8	D1		
Transported air temperature [°F (°C)]	-4...+104 (-20...+40)		
Regenerating efficiency [%]	≤ 93		
Ingress Protection	IP24		

MODEL	QUANTITY	COMMENTS	PROJECT
			location:
			architect:
			engineer:
			contractor:
			submitted by: