

VENTO EXPERT A50C3-1 S W V.2

Single-Room Heat Recovery Ventilator with Wi-Fi

Description

- o Vento Expert A50C3-1 S W V.2 designed to ensure filtration and supply of fresh air into the room as well as exhaust of stale air with energy regeneration. No freezing and condensation during operation.
- o Efficient supply and exhaust single-room ventilation air flow up to 30 CFM.



Key Features

- o Unique Single Room Heat Recovery Ventilator.
- o One Vento Expert unit in ventilation mode can serve rooms up to 500 sq. ft.*
- o Controlled by Android or iOS smartphone through the cloud server from any part of the world.
- o Wi-Fi communication between several ventilators for coordinated operation.
- o High-tech ceramic energy regenerator with max. heat recovery efficiency up to 93 %.
- o Built-in Humidity sensor, Timer and Weekly Scheduler.
- o Automatic air shutters.
- o Air cleaning with total MERV 5 class filters.
- o Antibacterial treatment of ERV core and filters.
- o Easy installation and maintenance.

*In accordance with ANSI/ASHRAE Standard 62.2-2016

Dimensions [in (mm)]

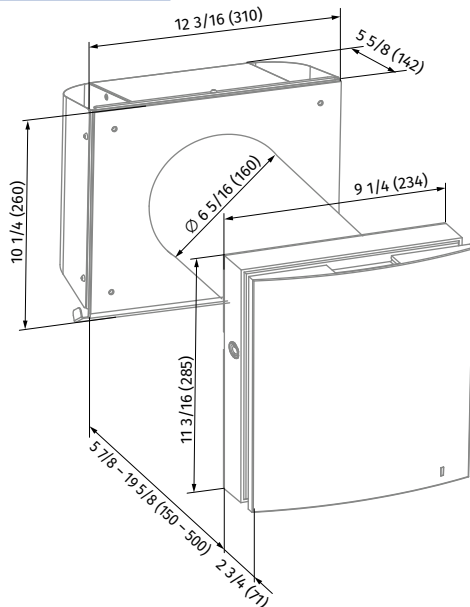

Motor

- o Reversible fan with EC motor.

Performance

Parameters	Vento Expert A50C3-1 S W V.2		
Speed	1	2	3
Supply voltage, 50/60 Hz [V]	1~100-240		
Power [W]	4.45	5.08	7.06
Max. current consumption [A]	0.035	0.040	0.059
Air flow in ventilation mode [CFM]	9	18	30
Air flow in regeneration mode [CFM]	4	9	15
RPM	800	1300	1900
Sound [Sones]	0.6	1.0	1.4
Noise attenuation according to DIN EN ISO 10140-2: 2010 [Sones]	2.5		
Indoor/outdoor airtightness classification of the complete unit in accordance with EN 13141-8	D1		
Transported air temperature [°F (°C)]	-13...104 (-25...+40)		
Regenerating efficiency [%]	≤ 93		
Ingress Protection	IP24		

MODEL	QUANTITY	COMMENTS	PROJECT
			location:
			architect:
			engineer:
			contractor:
			submitted by: