

VENTO EXPERT A85-1 W V.2

Single-Room Energy Recovery Ventilator with Wi-Fi



Description

- o Vento Expert A85-1 W V.2 designed to ensure filtration and supply of fresh air into the room as well as exhaust of stale air with energy regeneration. No freezing and condensation during operation.
- o Efficient supply and exhaust single-room ventilation air flow up to 50 CFM.



Key Features

- o Unique Single Room Energy Recovery Ventilator.
- o One Vento Expert unit in ventilation mode can serve room up to 500 sq. ft.*
- o Controlled by Android or iOS smartphone through the cloud server from any part of the world.
- o Wi-Fi communication between several ventilators for coordinated operation.
- o High-tech ceramic energy regenerator with max. heat recovery efficiency up to 70 %.
- o Built-in Humidity sensor, Timer and Weekly Scheduler.
- o Automatic air shutters.
- o MERV 5 filters (optionally MERV 13 filter).
- o Antibacterial treatment of ERV core and filters.
- o Easy installation and maintenance.

*In accordance with ANSI/ASHRAE Standard 62.2-2016

Dimensions [in (mm)]

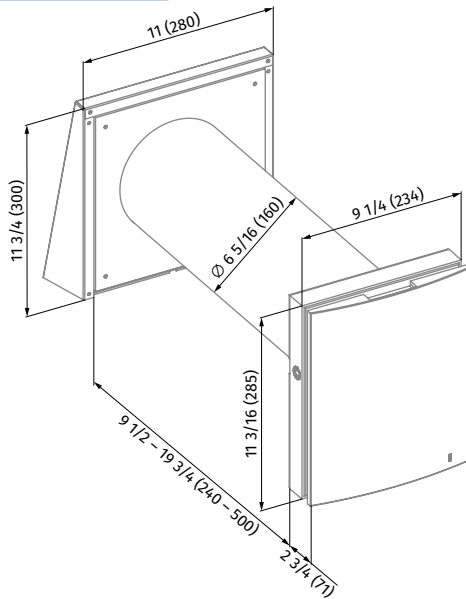

Motor

- o DC motor with outstanding low energy demand from 3.3 W. The fan is powered by safe voltage 12 V. The motor has integrated overheating protection and ball bearings for long service life.

Performance

Parameters	Vento Expert A85-1 W V.2			
Speed	I	II	III	max
Voltage / 50 (60) Hz [V]	1~100-240			
Power consumption [W]	3.3	3.84	4.65	9.68
Current consumption [A]	0.048	0.056	0.075	0.106
Air flow in ventilation mode [CFM]	9	18	30	50
Air flow in regeneration mode [CFM]	4	9	15	25
RPM	1050	1600	2270	2930
Sound [Sones]	0.7	1.5	3.0	4.3
Outdoor sound pressure attenuation [Sones]	2.5			
Transported air temperature [°F (°C)]	-4...+104 (-20...+40)			
Recovery efficiency [%]	≤ 70			
Regenerator material	Ceramic			
Filter	MERV 5 (Option: MERV 13)			
Ingress protection	IP24			

MODEL	QUANTITY	COMMENTS	PROJECT
			location:
			architect:
			engineer:
			contractor:
			submitted by: