

## TURBO-E EC 150

### Inline centrifugal fan

#### Description

- Supply and extract ventilation systems installed in various premises.
- Mounting in kitchens, bathrooms and other humid premises.
- Ventilation air ducts requiring high pressure, powerful air flow and low noise level.
- Compatible with  $\varnothing$  6" round air ducts.
- Compact size for limited spaces.



#### Casing

- Turbo-E EC fans combine the versatility and outstanding performance of both axial and centrifugal fans producing a powerful air flow and high pressure while retaining the signature energy-efficiency and response of EC motors.
- The casing of Turbo-E EC fan is made of low-combustible polypropylene. The removable central unit with a motor, impeller and terminal box is attached to the fittings by means of special mounting brackets with integral latches. This helps to make the fan maintenance extremely simple and convenient. Fan service no longer requires major disassembly and dismantling of the fan: all you have to do is remove the main unit from the casing and carry out the maintenance as required.
- The inlet fitting has a profiled header which ensures smooth air flow into the fan. Conically shaped impelles with specially profiled blades cause circular velocity rise, that results in airflow boost and pressure increase comparing to conventional design.
- The fan outlet combination of a diffuser, specially designed impeller and rectifier allow for the optimim air distribution: high air capacity and pressure without excessive noise.

#### Speed control

- The fans are controlled by means of a 0-10 V control signal while the performance regulation is based on the feedback from the temperature,

#### Overall dimensions [in]

Type	Duct dia	$\varnothing D$	B	H	L	Weight [lb]
Turbo-E EC 150	6"	5 13/16"	8 9/16"	11 3/8"	10"	5.07

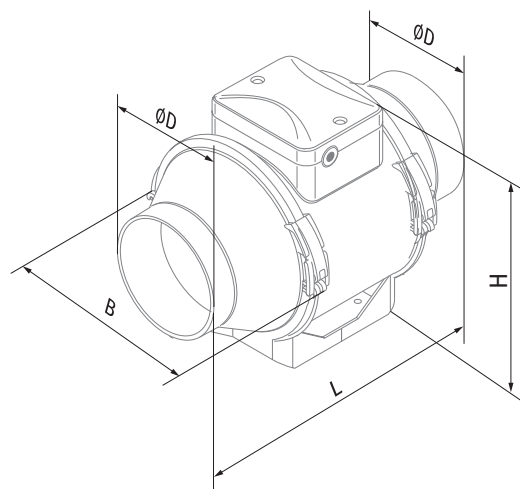

smoke and other sensors as well as other vital parameter settings. As the control signal changes the EC fan changes speed accordingly to supply the exact air amount required by the ventilation system.

- The maximum fan speed does not depend on the electric mains frequency enabling compatibility with both 50 Hz and 60 Hz networks. The fans can be easily combined into a single computer-controlled network. Special software allows for precise control over the operating parameters of the network units. All the system parameters can be monitored from the computer screen allowing to program operating parameters for each fan on the network individually.
- Integration of several fans into a single computer-controlled system with sensor feedback combined with speed control across the entire dynamic range.

#### Motor

- The fans feature high-efficiency electronically commutated (EC) direct current motors. These state-of-the-art units offer excellent energy efficiency. In addition to that EC motors combine high performance and optimum response over the entire speed range. The performance efficiency of electronically commutated motors reaches a staggering 90 %.

**Technical data**

Model	Duct dia	Energy Star compliance	RPM*	Sones	Watts*	Amps*	Max speed (10V) curve CFM vs. Static Pressure (Ps) in WG										Max Ps	Volts
							0"	0.125"	0.2"	0.25"	0.375"	0.5"	0.75"	1.0"	1.25"	1.5"		
Turbo-E EC 150	6"	yes	2800	2.6	52.4	0.54	343	328	318	311	293	272	222	143	66	8	1.53	120

\* The parameters RPM, Watts, Amps are indicated at 0.2 in WG static pressure.

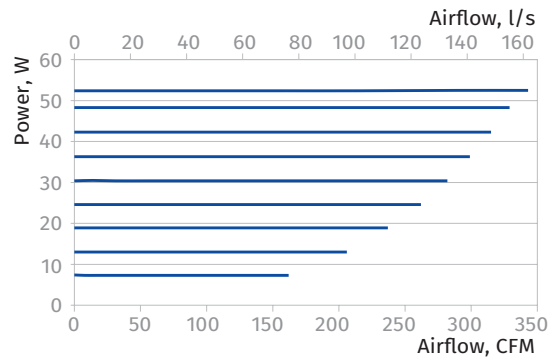
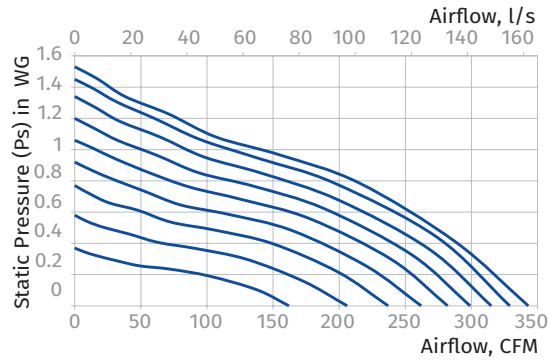

MODEL	QUANTITY	COMMENTS	PROJECT
			location:
			architect:
			engineer:
			contractor:
			submitted by: