

DESCRIPTION



ERV EC D 120

ENERGY RECOVERY VENTILATOR

ERV EC D 120 are the complete whole house ventilation system designed to bring a continuous supply of fresh air into the house while exhausting an equal amount of stale air.

Five year warranty.

CASING

Steel casing is covered with high-quality multilayer aluminum and zinc alloy to prevent corrosion.

The casing is equipped with a switch to turn the ventilator off when the service panel is opened.

FILTER

Washable MERV 6 air filters in exhaust and supply air streams. Optional supply: anti grease aluminum filter.

FANS

High efficient electronically commutated motors with external motor and impeller with forward curved blades. EC motors are featured with high performance and total speed controllable range. The electric motors and impellers are dynamically balanced.

ENERGY RECOVERY CORE

Enthalpic core (ERV EC D 120) provides both heat&humidity recovery. For enthalpic core no drain required.



DEFROST SYSTEM

To protect the Energy Recovery Core, an antifreeze electronic protection system is applied. It switches the supply fan off according to the temperature sensor settings. Warm extract air defrosts the ERV core then the supply fan switches on and the ventilator continues operating under rated conditions.

CONTROL BOARD

Terminals to connect external control devices

Three-position mode switch

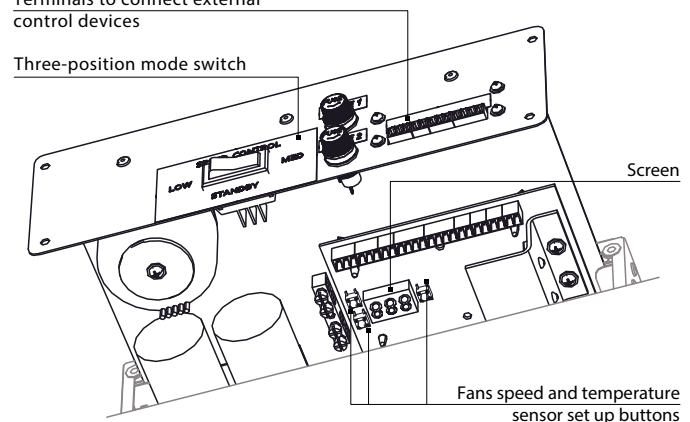

The unit incorporates an integrated control system with following functions:

- Operation mode switch.
- Airflow balancing enabled by supply and exhaust fan independent speed adjustment from 0 to 100% (percentage is displayed on built in screen).
- Automatic recovery core frost protection.
- External control device connection (up to 5 at the same time).

SUITABLE FOR:

Bathroom / kitchen / apartments / cottages / small offices.

PERFORMANCE

External Static Pressure		Net Supply Air Flow		Gross Air Flow				Power
				Supply		Exhaust		
Pa	in. W.G.	L/s	CFM	L/s	CFM	L/s	CFM	Watts
25	0.1	83	176	86	181	81	171	198
50	0.2	80	170	83	175	79	167	197
75	0.3	78	166	81	171	78	164	195
100	0.4	76	162	79	167	76	162	192
125	0.5	74	157	77	162	75	159	191
150	0.6	73	156	76	160	74	156	190
175	0.7	71	151	74	156	72	153	188
200	0.8	70	148	72	152	71	150	186
225	0.9	67	141	70	147	69	146	183
250	1	64	137	67	142	67	141	181
275	1.1	62	132	64	136	64	136	178
300	1.2	59	126	61	130	61	129	175
325	1.3	56	119	58	122	58	122	171
350	1.4	52	110	53	111	53	113	166
375	1.5	45	95	43	91	46	97	157
400	1.6	34	71	23	49	34	72	141
425	1.7	17	35	8	17	17	36	128
450	1.8	9	20	0	0	9	20	124

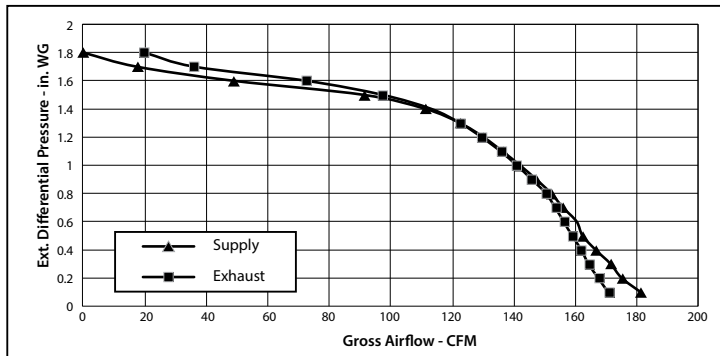

SOUND
1.5 Sones (30 L/s @ 50 Pa)

MODE	SUPPLY TEMPERATURE		NET AIR FLOW		AVERAGE POWER	SENSIBLE RECOVERY EFFICIENCY	APPARENT SENSIBLE EFFECTIVENESS	NET MOISTURE TRANSFER
	°C	°F	L/s	CFM	(Watts)	SRE (%)	ASEF (%)	
HEATING	0	32	31	66	23	66	66	0.42
	0	32	45	95	50	63	63	0.36
	0	32	50	106	66	62	62	0.34
COOLING	35	95	31	66	23	50	62	0.34

Model	Volts	Max. Watts	Max. Amps
ERV EC D 120	120V, 60Hz	198	2.5

DIMENSIONS

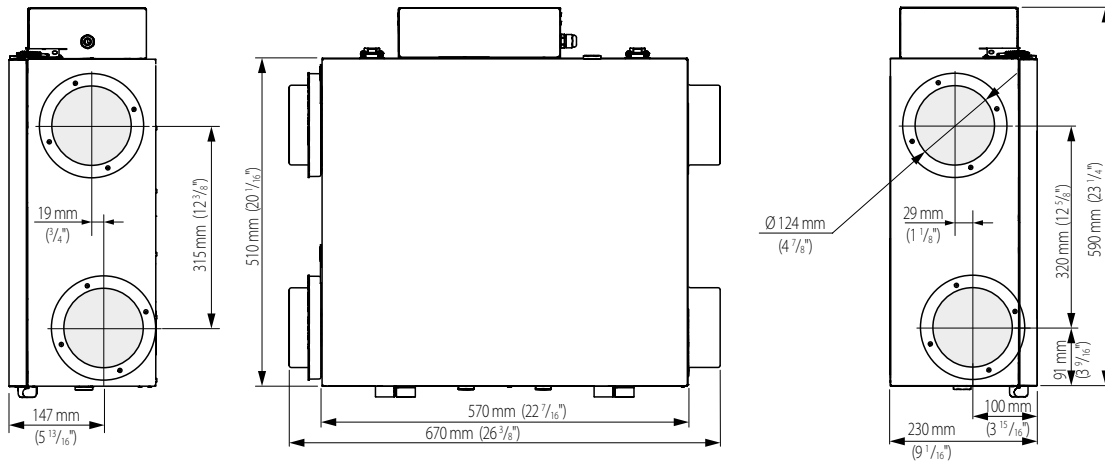

MODEL	QUANTITY	COMMENTS	PROJECT
			location:
			architect:
			engineer:
			contractor:
			submitted by:

