

DESCRIPTION

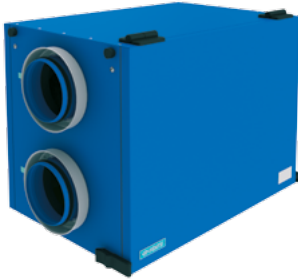

HRV H 200 HEAT RECOVERY VENTILATOR

A Heat Recovery Ventilator is a complete whole house ventilation system designed to bring a continuous supply of fresh air into the house while exhausting an equal amount of stale air.

- Efficient centralized recovery ventilation
- Cross flow core
- Silent operation
- Replaceable filters
- Simple installation and maintenance
- Compatible with 6" and 8" air ducts
- Electronic defrost protection

CASING

Steel casing is covered with high-quality multilayer aluminium and zinc alloy to prevent corrosion. The casing is equipped with a safety switch to turn the ventilator off when the service panel is opened.

FILTER

Washable MERV 6 air filters in exhaust and supply air streams.
Optional supply: anti grease aluminum filter.

HEAT RECOVERY CORE

Specially designed polymer plate core ensure the top heat recovery efficiency. Whenever heat recovery is not required for unit operation the heat exchanger block can be easily replaced by a "summer" block. The unit is also equipped with the drain pan for condensate.

DEFROST SYSTEM

To protect the heat recovery core, the electronic freezing protection system is applied. It switches the supply fan off as the temperature sensor requires. Warm extract air defrosts the heat recovery core, then the supply fan switches on and the ventilator continues operating under rated conditions.

MOTOR

German made high-efficient motor combined with backward inclined impeller delivers exceptionally powerful airflow and high static pressure. Built-in thermal overheating protection with automatic restart makes the motor operation secure and reliable. Permanently lubricated ball bearings inside the motor provide long (40000 hours) trouble- and maintenance-free operation.

FANS

The ventilator is equipped with supply and exhaust centrifugal fans with backward inclined blades and built-in thermal overheating protection with automatic restart. The electric motors and the impellers are dynamically balanced in two planes.

CONTROL

The ventilator is equipped with 3-step switch on it's side panel to choose STANDBY, LOW or MEDIUM mode for continuous operation. The unit can be equipped with wide range of additional controls (page 24) to switch boost on demand.

WARRANTY

5 year warranty

PERFORMANCE

Model	Volts	Max. Amps	Net Supply Air Flow CFM (l/s)												Duct Dia.
			Ext. Static Pressure in. wg (Pa)												
			0.1" (25Pa)	0.2" (50Pa)	0.3" (75Pa)	0.4" (100Pa)	0.5" (125Pa)	0.6" (150Pa)	0.7" (175Pa)	0.8" (200Pa)	0.9" (225Pa)	1.0" (250Pa)	1.2" (275Pa)	1.4" (300Pa)	
HRV H 200	120V, 60Hz	1.8	213 (101)	200 (94)	187 (88)	173 (82)	159 (75)	145 (68)	130 (61)	117 (55)	101 (48)	87 (41)	71 (34)	56 (26)	6"

Model	Mode	Temperature		Net Air Flow		Power Consumed (Watts)	Sensible Recovery Efficiency SRE (%)
		°C	°F	(l/s)	(cfm)		
HRV H 200	HEATING	0	32	30	64	208	85
		0	32	45	95	210	83
		0	32	60	127	212	81

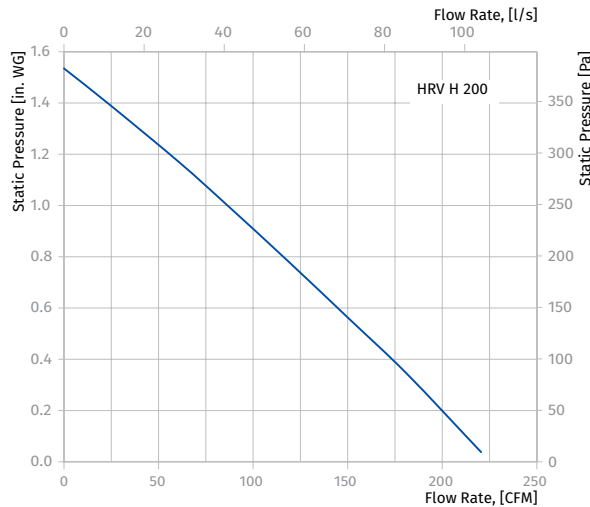

DIMENSIONS

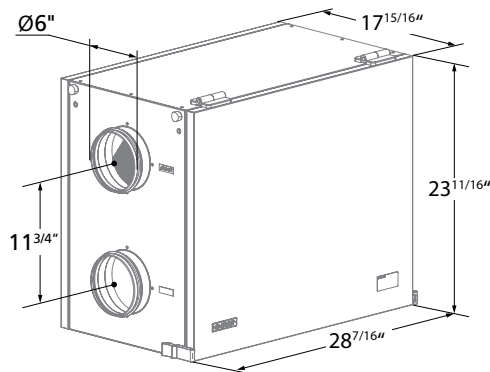

MODEL	QUANTITY	COMMENTS	PROJECT
			location:
			architect:
			engineer:
			contractor:
			submitted by: